

Six-Lobe 100° Flat  
Phillips Round Washer

HEAD DIMENSIONS

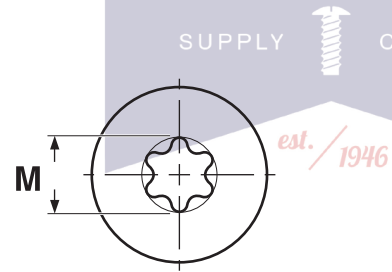
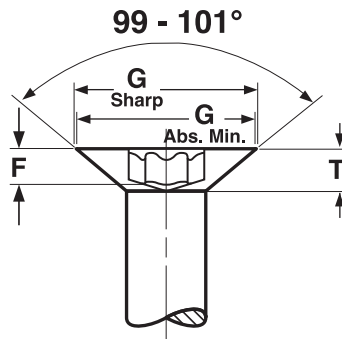

SIX-LOBE 100° FLAT HEAD FOR MACHINE SCREWS

Camcar  
Textron

Nominal Size	T	G		M	F	Fallaway Maximum Penetration of No-Go Gauge	Driver Size
	Head Height	Head Diameter		Recess Diam.	Gauge Penetration		
	Ref	Max Sharp	Abs. Min	Ref	Ref	Max	
2	.0216	.171	.143		.020		T6
4	.049	.225	.191	.094	.020	.019	T8
6	.060	.279	.238	.111	.035	.022	T10
8	.072	.332	.285	.132	.046	.026	T15
10	.083	.385	.333	.155	.056	.031	T20
1/4	.110	.507	.442	.221	.085	.044	T30
5/16	.138	.635	.556	.266	.092	.047	T40
3/8	.165	.762	.670	.312	.110	.055	T45

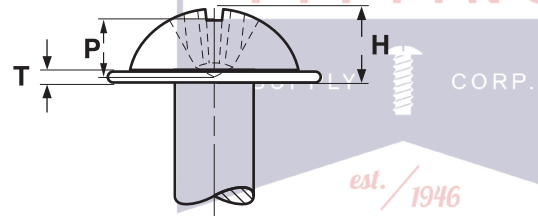
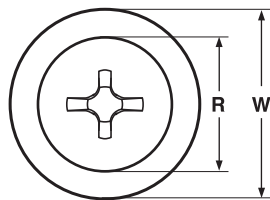

PHILLIPS ROUND WASHER HEADS FOR MACHINE SCREWS

ASME B18.6.3 2010

Nominal Size	R	H		W		T	D	Recess Penetrating Gaging Depth		Driver Size
	Crown Diameter	Head Height		Washer Diameter		Washer Thickness	Recess Diameter			
	Ref	Max	Min	Max	Min	Ref	Ref	Max	Min	
4	.177	.079	.067	.261	.243	.030	.116	.065	.044	1
6	.218	.096	.084	.321	.301	.040	.147	.061	.033	2
8	.259	.113	.101	.380	.358	.040	.161	.076	.048	2
10	.300	.130	.118	.439	.416	.050	.177	.093	.066	2
12	.341	.148	.134	.498	.473	.050	.228	.094	.066	3
1/4	.396	.170	.157	.576	.548	.050	.244	.107	.080	3
5/16	.494	.211	.197	.719	.687	.060	.292	.156	.129	3