











LEGEND

Applications

 Washing	 Hammering
 Professional washing	 Screwing
 Air/water spraying	 Professional screwing
 Air/water professional spraying	 Orbital sanding
 Inflating	 Professional orbital sanding
 Blowing	 Rotorbital sanding
 Professional blowing	 Rotorbital polishing
 Nailing	 Hobby painting
 Spray pistoling	 Painting
 Impact wrenching	 Professional gravity painting
 Light hammering	 Professional grinding
 Sandblasting	

Technical data symbols

 Tank capacity	 Voltage
 Air displacement	 Pressure in bar
 Motor power	 Noise level dB(A)
 Dimensions in mm	 Weight in kg
 N° unit	 Stages
 Fad	 Cylinders
 Barcode	 Fuel
 Pump	

Conversion table:

1 m³/min = 35,314 cfm
 C° = (F°-32) x 5/9
 1 bar = 14,50 psi
 1 bar = 100 kPa
 1 kg = 2,2 lbs
 1 lt = 0,26 gall (USA)

Index

The range of productspage 4

PISTON COMPRESSORS

BASE Line rangepage 7
 LINE rangepage 11
 PRO LINE rangepage 19
 SILENCED range.....page 49
 TRADE Line range.....page 59
 cleanAIR rangepage 63
 engineAIR range.....page 69

PUMPS

Oil free direct driven.....page 76
 Lubricated direct drivenpage 77
 Single stage belt driven.....page 78
 Two-stage belt driven.....page 79

AIR TREATMENT

Quality Airpage 82
 COOL rangepage 83
 DRY rangepage 84
 HAD range.....page 86
 Filterspage 88
 Condensate drainspage 93
 Oil-water separatorspage 94
 Centrifugal condensate separatorspage 96
 Vertical tankspage 97

Three steps to select the right compressor

1. What type of applications do you need your piston for?

Use the formula to determine the required air displacement and define your place in the matrix below:

$$(l/min \text{ usage of tool } x + l/min \text{ tool } y + l/min \text{ tool } n) + 25\% \text{ of total } l/min$$

2. With what frequency will you use your compressor?

Occasional use:

If you only need a compressor from time to time for typically less demanding applications such as blowing, inflating and nailing. This technology comes both oil-lubricated and oil-less, the latter one providing less maintenance and oil spillage free services.

Intermittent use:

More frequent and intensive use of a compressor suitable for a professional environment will lead you to our belt driven technology with singular compression. These compressors are fit to perform all the tasks mentioned above, but can also be used for painting, ratcheting, wrenching, and many more applications.

Frequent use:

Last but not least, dual stage compressors offer a higher air flow and can reach up to 15 bar pressure. This makes them the ideal choice for frequent and more intensive applications such as hammering, impact wrenching, grinding,...

3. What level of user comfort do you expect?

As the ABAC customer is continuously in mind when designing new products, enhanced reliability and usability can always be expected. Our full offer comes in three levels adding extra features to increase the users comfort. All levels of course still offer the well-known ABAC benefits such as plug and play air solutions, always available and ready to use. Each level distinguishes a specific target group.

Have the answers ready? Check out the product matrix to get a strong grip on your customers' needs

Orbital polisher 300 l/min	+	Ratchet wrenching 200 l/min	+	Air pistol 100 l/min	+	25% of total l/min 150 l/min	=	750 l/min
-------------------------------	---	--------------------------------	---	-------------------------	---	---------------------------------	---	-----------

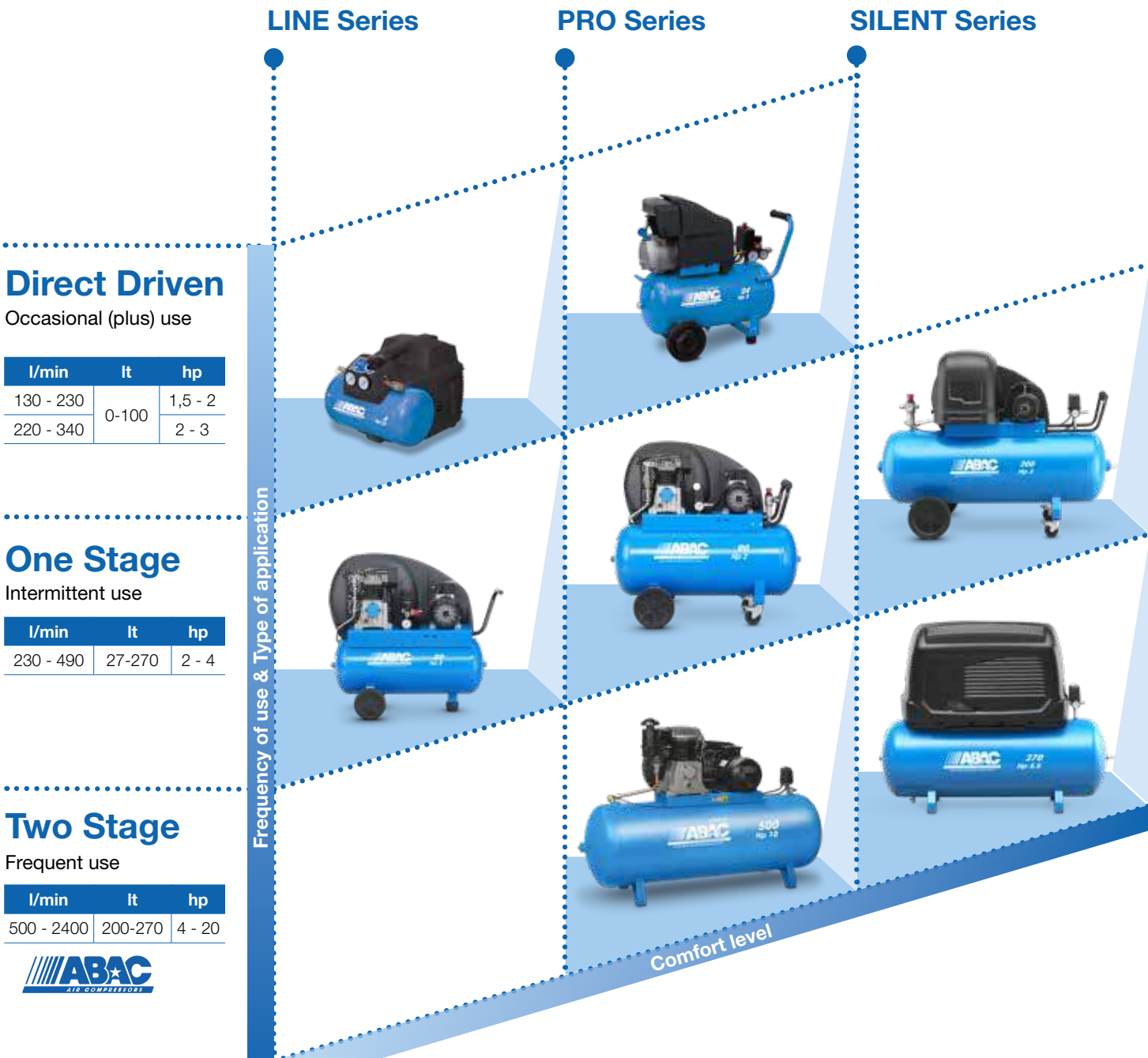

Direct Driven

Occasional (plus) use

l/min	lt	hp
130 - 230	0-100	1,5 - 2
220 - 340		2 - 3

One Stage

Intermittent use

l/min	lt	hp
230 - 490	27-270	2 - 4

Two Stage

Frequent use

l/min	lt	hp
500 - 2400	200-270	4 - 20



Products range

BASE Line



Direct driven air compressors with piston range B15

Single stage, oil free, with powers from 1.5 HP, tank up to 24 litres, operating pressure from 1 to 8 BAR.

Direct driven air compressors with piston range B20

Single stage, Direct Driven, lubricated, with power ratings from 2 HP, tank capacity from 24 to 50 litres, operating pressure from 1 to 8 BAR.

Belt driven air compressors with pistons range B26

Single stage, belt driven, lubricated, with power ratings from 2 to 3 HP, tank capacity from 27 to 200 litres, working pressure 9 BAR.

LINE



Direct driven air compressors with piston range O15

Oil free, single stage, Direct Driven, with powers from 1.5 HP, tanks up to 24 litres, working pressure from 1 to 8 BAR.

Direct driven air compressors with pistons range L20

Single stage, Direct Driven, lubricated, with power ratings from 2 to 6 HP, 50 litres tank, working pressure from 1 to 8 BAR.

Belt driven, Single Stage air compressors with pistons

With two cylinders, lubricated, with power ratings from 2 to 3 HP, 27 to 270 litres tank, working pressure from 1 to 10 BAR.

PRO



Direct driven air compressors with pistons range O20

Single stage, oil free, Direct Driven with 2HP power, tank from 6 to 50 litres fuel tank, working pressure from 1 to 8 BAR.

Direct driven air compressors with pistons range L25P and L30P

Single stage, Direct Driven, lubricated, with power ratings from 2.5 to 3 HP, tank capacity from 24 to 50 litres, working pressure from 1 to 10 BAR.

Direct driven air compressors with pistons range V

Single stage, Direct Driven, "V" twin-cylinders, lubricated, with 3 HP power, tank capacity from 9+9 to 90 litres, working pressure from 1 to 10 BAR.

Belt driven, Single Stage air compressors with pistons

Two cylinders, lubricated, with power ratings from 2 to 4 HP, 27 to 270 litres tank, working pressure from 1 to 10 BAR.

Belt driven, Two Stage air compressors with pistons

Two cylinders, lubricated, with power ratings from 4 to 20 HP, 200 to 900 litres tank, working pressure from 1 to 11 BAR.

Belt driven, Two Stage air compressors with pistons range tandem and on base

Two cylinders, lubricated, with power ratings from 4 to 20 HP, tank capacity from 270 to 900 litres, working pressure from 1 to 11 BAR. Decades of experience in the field of compressed air.

SILENCED



Belt driven two stage or single stage, with two cylinders, lubricated, with power ratings from 2 to 10 HP, tank up to 500 litres, working pressure from 1 to 11 BAR.

TRADE Line



110 Volts belt and direct driven air compressors

Tanks from 6 to 50 litres, pressure 8 and 10 BAR.

cleanAIR



Oil free direct driven air compressors

Power from 1.5 to 2.5 HP, oil free, tanks for up to 50 litres, working pressure 8 BAR. Available with desiccant dryer & silenced enclosure. Compliant with HTM2022 for Dental Air applications.

engineAIR



Petrol engine air compressors

Two cylinders lubricated, single and two stage with belt drive, 11 + 11 tanks to 270 litres, power ratings from 4 to 12 HP, 10 and working pressure 10 and 14 BAR, diesel and petrol engines.

PUMPS



Direct and belt driven, oil free and lubricated with a complete range of highly reliable pump units all designed and manufactured in house.

AIR TREATMENT



To allow a better use, whether industrial, professional or hobby use, with all major compressed air tools and accessories: from the tanks to the dryers, from filters to condensate drains.



BASE Line

Essential and reliable
Complete and functional
Simple and easy to use





Direct and belt driven compressors

BASE Line range

BASE Line products are the solution to meet the needs of all hobbyists. Simple and reliable compressed air.

Applications

Direct Driven

1,5 - 3 hp • 160 - 240 l/min

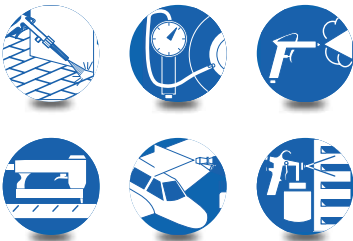

Safety

Sturdy plastic cover

Easy to use

Switching on and off and pressure setting



VENTO B15
2 hp - 6 litres - oil free

Safe

No oil leaks

Model	Part No	L	L/min	CFM	HP	KW	RPM	Voltage	Bar	L x W x H (mm)	kg
VENTO B15 BASELINE	1129100011	6	160	5.7	1,5	1,1	2450	230/50/1	8	385x300x510	11
POLE POSITION B15 BASELINE	1129100017	24	160	5.7	1,5	1,1	2450	230/50/1	8	600x320x580	18
POLE POSITION B20 BASELINE	1129100016	24	190	6.7	2	1,5	2850	230/50/1	8	600x320x595	24
MONTECARLO B20 BASELINE	1129100015	50	190	6.7	2	1,5	2850	230/50/1	8	760x410x660	32

*Run off a 13 Amp supply



MONTECARLO B20
2 hp - 50 litres - lubricated



Carry by hand



Output air regulators and quick coupling



B26/90 CM2
2 hp, 100 litres - lubricated

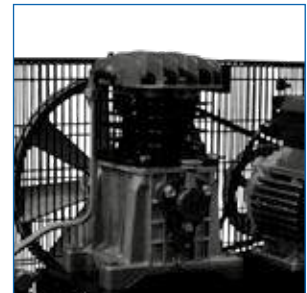

Single stage compressor pump unit with cast iron cylinder for longer life

Model	Part No	L	L/min	CFM	HP	KW	RPM	Voltage	Bar	L x W x H (mm)	kg
B26/50 CM2 BASELINE	1121450011	50	210	7.4	2	1,5	1400	230/50/1	10	1010x360x730	50
B26/90 CM2 BASELINE	1121450017	90	240	8.4	3	2,2	1600	230/50/1	10	1100x400x830	64
B26B/150 CM3 BASELINE	1121450019	150	240	8.5	3	2,2	1600	230/50/1	10	1360x540x1060	90
B26B/200 CM3 BASELINE	1121450020	200	240	8.5	3	2,2	1600	230/50/1	10	1460x6400x1140	102

*Run off a 13 Amp supply



LINE

*Light and compact
Easy to carry or move
Simple and straightforward use
Reliable operation*





Oil Free direct driven compressors

O15 range

The O15 range offers great solutions for performing smaller compressed air applications in and around the house.

Applications

Direct Driven
1,5 • 180 l/min

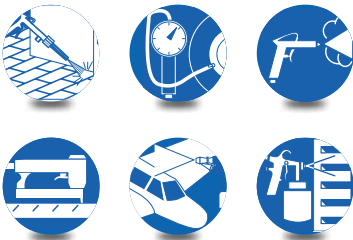

User-friendly
Simple connection

Maneuverable
Light and easy to carry



COMPY O15
1,5 hp, oil free

Comfort
Small footprint

Safety
No oil spillage

Model	Part No	L	L/min	CFM	HP	KW	RPM	Voltage	Bar	dB(A)	L x W x H (mm)	kg
COMPY O15	1129100215	-	180	6.4	1,5	1,1	2450	230/501	8	68	390x270x240	4
START O15	1129100201	6	180	6.4	1,5	1,1	2450	230/501	8	68	310x385x290	10
POLE POSITION O15	1129100203	24	180	6.4	1,5	1,1	2450	230/501	8	68	600x325x500	16

*Run off a 13 Amp supply



START O15
1,5 hp, 6 litres, oil free



Strong and easy to handle



ON/OFF switch



Big pressure regulator



POLE POSITION O15
1,5 hp, 24 litres, oil free



Can be carried by hand



Oil lubricated direct driven compressors

L20 range

Performing small tasks has never been this simple and easy using the L20 range of compressors.

Applications

Direct Driven

2 hp • 220l/min

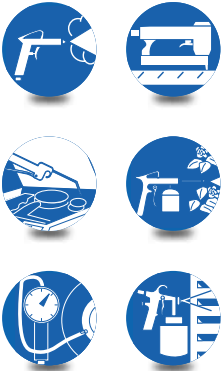

MONTECARLO L20
2 hp, 50 litres

Model	Part No	L	L/min	CFM	HP	KW	RPM	Voltage	Bar	dB(A)	L x W x H (mm)	kg
START L20	1129100226	6	220	7.8	2	1,5	2850	230/50/1	10	70	370x285x480	14
POLE POSITION L20	1129100202	24	220	7.8	2	1,5	2850	230/50/1	10	70	600x325x605	25
MONTECARLO L20	1129100178	50	220	7.8	2	1,5	2850	230/50/1	10	70	760x420x665	33

*Run off a 13 Amp supply





START L20
2 hp, 6 litres



Carry by hand



User-friendly and clear gauges



POLE POSITION L20
2 hp, 24 litres



Large and easy to operate drain valve



Stability



Single stage belt driven compressors

A29 range

Belt driven technology developed for simple but reliable operation.

Applications

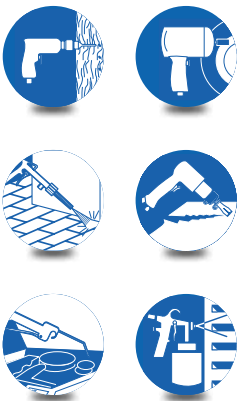

Innovative design
Belt guard improving air cooling

Reliable
Cast iron cylinder

Performance
Slow speed pump reduces temperature

User-friendly
Easy oil check and refilling



A29B 90 FT3
3 hp, 90 litres

Model	Part No	L	L/min	CFM	HP	KW	RPM	Voltage	Bar	dB(A)	L x W x H (mm)	kg
A29 27 CM2	4116024559	27	255	8.9	2	1,5	1075	230/50/1	10	93	810 x 390 x 710	43
A29 50 CM2	4116024558	50	255	8.9	2	1,5	1075	230/50/1	10	93	870 x 370 x 780	49
A29 90 CM2	4116024555	90	255	8.9	2	1,5	1075	230/50/1	10	93	1010 x 415 x 900	56
A29 150 CM2	4116024554	150	255	8.9	2	1,5	1075	230/50/1	10	93	1375 x 420 x 950	87
A29B 50 CM3	4116024869	50	320	11.2	3	2,2	1300	230/50/1	10	95	940 x 410 x 800	58

* Single phase run off a 13 Amp supply



A29 50 CM2
2 hp, 50 litres



Stable and strong



Large and easy to operate
drain valve



A29B 150 FM3
3 hp, 150 litres

Model	Part No	L	L/min	CFM	HP	KW	RPM	Voltage	Bar	dB(A)	L x W x H (mm)	kg
A29B 90 CM3	4116024870	90	320	11.2	3	2,2	1300	230/50/1	10	95	1010 x 415 x 900	56
A29B 90 FM3	4116024886	90	320	11.2	3	2,2	1300	230/50/1	10	95	1010 x 415 x 900	56
A29B 90 FT3	4116024526	90	320	11.2	3	2,2	1300	400/3/50	10	95	1010 x 415 x 900	56
A29B 150 FM3	4116024871	150	320	11.2	3	2,2	1300	230/50/1	10	95	1375 x 420 x 950	87
A29B 150 FT3	4116024533	150	320	11.2	3	2,2	1300	400/3/50	10	95	1375 x 420 x 950	87
A29B 150 CM3	4116024885	150	320	11.2	3	2,2	1300	230/50/1	10	95	1500 x 470 x 1110	91
A29B 200 FM3	4116024888	200	320	11.2	3	2,2	1300	230/50/1	10	95	1500 x 470 x 1110	91
A29B 200 CM3	4116024887	200	320	11.2	3	2,2	1300	230/50/1	10	95	1375 x 420 x 950	87

* Single phase run off a 13 Amp supply



PRO Line

*Advanced user-friendliness
Maximum comfort
Increased performance
Ultimate durability and efficiency*





Oil free direct driven compressor

O10P & O20P range

High performance with an oil free pump.

Safety

No oil spillage

Comfort

Rubber grip for more control

Applications



User-friendly

Reliable and easy to switch ON/OFF

POLE POSITION O20P

2 hp, 24 litres, oil free

Maneuverable

Bigger wheels for better handling

Model	Part No	L	L/min	CFM	HP	KW	RPM	Voltage	Bar	dB(A)	L x W x H (mm)	kg
SILENT START O10P	1121020391	6	130	4.6	1	0,7	1450	230/50/1	8	66	530x210x540	15
START O20P	1121020090	6	230	8.1	2	1,5	2850	230/50/1	8	75	375x310x530	14
POLE POSITION O20P	1121210968	24	230	8.1	2	1,5	2850	230/50/1	8	75	660x300x650	22
MONTECARLO O20P	1121360802	50	230	8.1	2	1,5	2850	230/50/1	8	75	770x410x730	30

* Single phase run off a 13 Amp supply



START O20P
2 hp, 6 litres, oil free



Strong and easy handling



Safe transportation:
no oil spillage



MONTECARLO O20P
2 hp, 50 litres, oil free



Big pressure gauges for
easy reading



Safe and strong cover



Oil lubricated direct driven compressor

L25P - L30P range

Professional and compact performance with extra user-friendly benefits.

Applications



Performance
Large and cooled air flows and bumper

POLE POSITION L30P
3 hp, 24 litres

Flexible
Strong big wheels

Reliable
Quick and easy draining

Model	Part No	L	L/min	CFM	HP	KW	RPM	Voltage	Bar	dB(A)	L x W x H (mm)	kg
POLE POSITION L25P	1129100227	24	270	9.5	2,5	1,9	2850	230/50/1	10	73	660x300x605	28
MONTECARLO L25P	1129100239	50	270	9.5	2,5	1,9	2850	230/50/1	10	73	940x320x700	36
POLE POSITION L30P	1129100173	24	310	11	3	2,2	2850	230/50/1	10	73	660x300x605	29
MONTECARLO L30P	1129100199	50	310	11	3	2,2	2850	230/50/1	10	73	940x320x700	37

* Single phase run off a 13 Amp supply



POLE POSITION L25P
2,5 hp, 24 litres



Big pressure gauges for easy reading



Integrated oil sight glass in the pump



MONTECARLO L30P
3 hp, 50 litres

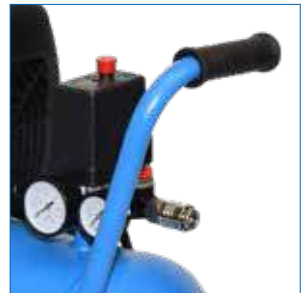

Ergonomic rubber handle



High performance pump with aftercooler



Oil free and lubricated direct driven compressors

Special configurations

More specific needs require more specific configurations.

Applications

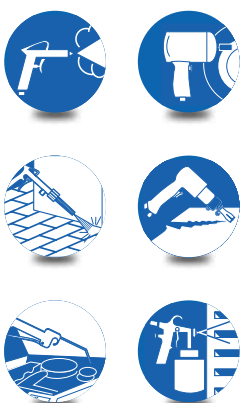

PORTABLE ROLLCAGE L30P 3 hp, 9 litres



Comfort
Foldable high handle

User-friendly
Clear and nicely
designed regulators

Flexible
Dual outlet
to multi task

Comfort
Large wheels and strong bumpers

Model	Part No	L	L/min	CFM	HP	KW	RPM	Voltage	Bar	dB(A)	L x W x H (mm)	kg
START ROLLCAGE O20P	1121020310	9	230	8.1	2	1,5	2850	230/50/1	8	75	455x475x500	21
SILVERSTONE O20P	1121020311	10	230	8.1	2	1,5	2850	230/50/1	8	75	420x330x635	20
START ROLLCAGE L25P	1129100520	9	270	9.5	2,5	1,9	2850	230/50/1	10	73	455x475x500	24
SILVERSTONE L25P	1129100246	10	270	9.5	2,5	1,9	2850	230/50/1	10	73	420x330x635	24
PORTABLE ROLLCAGE L30P	1129100217	9	310	11	3	2,2	2850	230/50/1	10	75	480x510x550	29
HOCKENHEIM L30P	1129100247	20	310	11	3	2,2	2850	230/50/1	10	75	520x430x790	35

* Single phase run off a 13 Amp supply



HOCKENHEIM L30P
3 hp, 20 litres



Double handle providing extra user comfort



Big pressure gauges for easy reading



START ROLLAGE O20P
2 hp, 9 litres, oil free



Stability improving and noise reducing dampers



Safe and more comfortable to carry around



Oil lubricated direct driven compressors

High performance V range

High performance in a compact compressors.
Designed for intensive use.

Applications

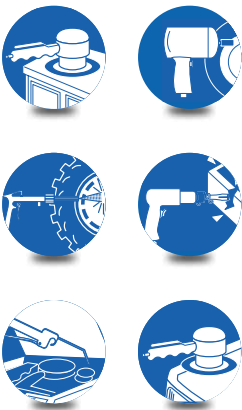

User-friendly

Extra tray to place materials and equipment

Comfort

Extendable handle with extra rubber grip



Safety

Rollbar for extra protection

Stable

Large inflatable wheels perfect for uneven surfaces

PRO V30 9+9 CM3

3 hp, 9+9 litres

Model	Part No	L	L/min	CFM	HP	KW	RPM	Voltage	Bar	dB(A)	L x W x H (mm)	kg
V30/9+9 CM3	1121440198	9+9	330	11.7	3	2,2	1450	230/50/1	10	72	770x610x540	50
V30/20 PCM3	1121090865	20	330	11.7	3	2,2	1450	230/50/1	10	72	520x430x790	43
V30/50 CM3	1121360260	50	330	11.7	3	2,2	1450	230/50/1	10	72	800x380x680	60
V30/50 VERTICAL	1121430260	50	330	11.7	3	2,2	1450	230/50/1	10	72	520x410x1100	62
V30/90 CM3	1121370233	90	330	11.7	3	2,2	1450	230/50/1	10	72	1200x400x830	72

* Single phase run off a 13 Amp supply





PRO V30 20 PCM3
3 hp, 20 litres

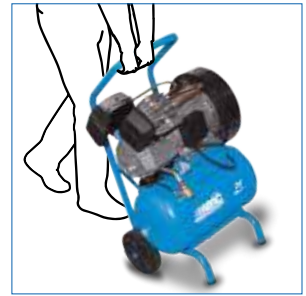

Double handle providing extra user comfort



Compact and efficient configuration



PRO V30 50 VERTICAL
3 hp, 50 litres



Long handle for easy moving



Space saving with small footprint



Single stage belt driven compressors

A29B PRO range

More user friendliness and lower operating temperatures.

Applications

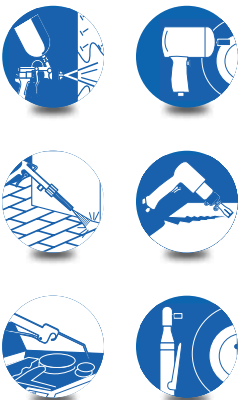

Innovative design
Belt guard improving air cooling

Long-lasting
Slow speed pump design reducing temperatures

Performance
Aftercooler as standard

Flexible
Dual outlet



PRO A29B 90 CM2
2 hp, 90 litres

User-friendly
Big wheels and lockable pivot wheels

Model	Part No	L	L/min	CFM	HP	KW	RPM	Voltage	Bar	dB(A)	L x W x H (mm)	kg
PRO A29B 27 CM2	4116024557	27	255	8.9	2	1,5	1075	230/50/1	10	93	810 x 390 x 710	43
PRO A29B 50 CM2	4116024556	50	255	8.9	2	1,5	1075	230/50/1	10	93	870 x 370 x 780	49
PRO A29B 90 CM2	4116024553	90	255	8.9	2	1,5	1075	230/50/1	10	93	1010 x 415 x 900	56
PRO A29B 90 FM2	4116024552	90	255	8.9	2	1,5	1075	230/50/1	10	93	1010 x 415 x 900	56

* Single phase run off a 13 Amp supply



PRO A29B 50 CM2
2 hp, 50 litres



Slow speed, low temperature, low noise



Safe and strong grip to move unit



Large and easy to operate drain valve



PRO A29B 150 CM2
2 hp, 150 litres



Double outlet for dual operation

Model	Part No	L	L/min	CFM	HP	KW	RPM	Voltage	Bar	dB(A)	L x W x H (mm)	kg
PRO A29B 150 CM2	4116024550	150	255	8.9	2	1,5	1075	230/50/1	10	93	1375 x 420 x 950	87
PRO A29B 150 FM2	4116024551	150	255	8.9	2	1,5	1075	230/50/1	10	93	1375 x 420 x 950	87
PRO A29B 50 CM3	4116024949	50	317	11.2	3	2,2	1050	230/50/1	10	93	847 x 395 x 796	45
PRO A29B 90 CM3	4116024950	90	317	11.2	3	2,2	1050	230/50/1	10	93	968 x 474 x 870	52

* Single phase run off a 13 Amp supply



Single stage belt driven compressors

A39B PRO range

Reliable power and performance in combination with user friendly features.

Performance

Belt guard improves airflow over pump

Reliable

Reduced wear thanks to great cooling

Applications

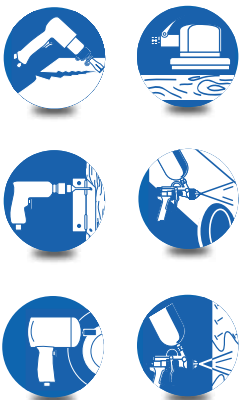

PRO A39B 200 FM3

3 hp, 200 litres

Model	Part No	L	L/min	CFM	HP	KW	RPM	Voltage	Bar	dB(A)	L x W x H (mm)	kg
PRO A39B 90 CM3	4116025017	90	393	13.8	3	2,2	1050	230/50/1	10	93	1180 x 460 x 930	72
PRO A39B 90 FT3	4116024530	90	393	13.8	3	2,2	1050	400/3/50	10	93	1180 x 460 x 930	72
PRO A39B 150 FM3	4116025015	150	393	13.8	3	2,2	1050	230/50/1	10	93	1375 x 420 x 950	87
PRO A39B 150 FT3	4116024539	150	393	13.8	3	2,2	1050	400/3/50	10	93	1375 x 420 x 950	87
PRO A39B 200 FM3	4116025016	200	393	13.8	3	2,2	1050	230/50/1	10	93	1500 x 470 x 1110	91
PRO A39B 200 CM3	4116025022	200	393	13.8	3	2,2	1050	230/1/50	10	93	1500x470x1110	91

* Single phase run off a 16 Amp supply



PRO A39B 150 FM3
3 hp, 150 litres



Slow speed, low temperature,
low noise



Unique innovative belt guard
design to improve cooling



PRO A39 270 FM3 TANDEM
3hp, 270 litres



Reliable and easy to use

Model	Part No	L	L/min	CFM	HP	KW	RPM	Voltage	Bar	dB(A)	L x W x H (mm)	kg
PRO A39B 200 FT3	4116024541	200	393	13.8	3	2,2	1050	400/3/50	10	93	1500x470x1110	91
PRO A39B 270 FT3	4116024543	270	393	13.8	3	2,2	1050	400/3/50	10	93	1530x595x1160	138
PRO A39B 270 FM3 TANDEM	4116024868	270	786	27.6	3+3	2,2+2,2	1050	230/50/1	10	93	1570x470x1030	153

* Tandem single phase unit requires a 32amp single phase supply



Two stage belt driven compressors

PRO B4900-B7000

Two stage compression providing bigger flows and higher pressure.

Applications

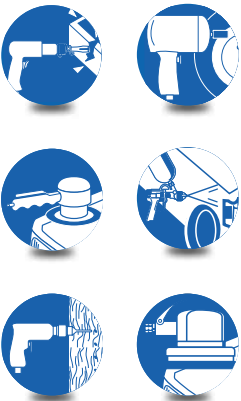

User-friendly

Clear oil level indicators

Performance

Proven and well established technology



Durable

Strong components

PRO B5900B 200 FT5,5

5,5 hp, 200 litres

Model	Part No	L	L/min	CFM	HP	KW	RPM	Voltage	Bar	L x W x H (mm)	kg
PRO B4900 200 FT4	4116019614	200	514	18.0	4	3	1400	400/3/50	11	1500x450x960	137
PRO B5900B 200 FT5,5	4116019759	200	653	22.9	5,5	4	1400	400/3/50	11	1580x580x1150	161
PRO B6000 270 FT7,5	4116020193	270	827	28.9	7,5	5,5	1400	400/3/50	11	1520x600x1250	177
PRO B7000 270 FT10 YD	4116020794	270	1210	42.4	10	7,5	1300	400/3/50	11	1520x600x1250	196



PRO B4900 200 FT4
4 hp, 200 litres



Two stage compressor pump with cast iron cylinder for longer life



Finned aftercooler to lower the compressed air temperature



PRO B6000 270 FT7,5
7,5 hp, 270 litres



Two stage compressors with tankmounted dryer

FFO range

An all-in-one range professional piston compressors.

Applications

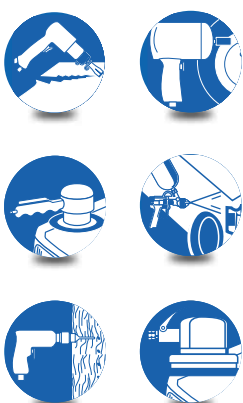

User-friendly
Pre-connected dryer

Efficient
No separate installation



B4900 270 FT4 FFO
4 hp, 270 litres, Full Feature

Comfort
Space saving solution

Model	Part No	L	L/min	CFM	HP	KW	RPM	Voltage	Bar	L x W x H (mm)	kg
B4900 270 FT4 FFO	4116000158	270	514	18.0	4	3	1400	400/3/50	11	1490 x 500 x 1175	174
B5900B 270 FT5,5 FFO	4116000159	270	653	22.9	5,5	4	1400	400/3/50	11	1490 x 500 x 1175	197
B5900B 500 FT5,5 FFO	4116000165	500	653	22.9	5,5	4	1400	400/3/50	11	1894 x 600 x 1280	249
B6000 270 FT7,5 FFO	4116000166	270	827	28.9	7,5	5,5	1400	400/3/50	11	1490 x 500 x 1175	207



B7000 500 FT10 FFO YD
10 hp, 500 litres, Full Feature



Dryer connected



Flexibility to bypass dryer



Tank mounted space-saving

Model	Part No	L	L/min	CFM	HP	KW	RPM	Voltage	Bar	L x W x H (mm)	kg
B6000 500 FT7,5 FFO	4116000167	500	827	28.9	7,5	5,5	1400	400/3/50	11	1894 x 600 x 1280	290
B7000 270 FT10 FFO YD	4116000175	270	1210	42.4	10	7,5	1300	400/3/50 YD	11	1490 x 500 x 1175	231
B7000 500 FT10 FFO YD	4116000176	500	1210	42.4	10	7,5	1300	400/3/50 YD	11	1894 x 600 x 1280	314



Single and two stage belt driven compressors

Vertical PRO

Vertical air receiver compressors provide a space saving solution in the workshop.

Long-lasting
Strong heavy duty components

Performance
Two stage
high air volume pump

Applications

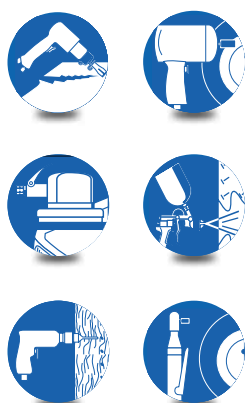

PRO B5900B 270 VT5,5
5,5 hp, 270 litres, vertical

Small footprint
Space saving

Model	Part No	L	L/min	CFM	HP	KW	RPM	Voltage	Bar	L x W x H (mm)	kg
PRO A39B 150 VM3	4116025019	150	393	13.8	3	2,2	1050	230/50/1	10	850x970x1950	160
PRO A39B 150 VT3	4116024162	150	393	13.8	3	2,2	1050	400/3/50	10	850x970x1950	160
PRO B4900 150 VT4	4116024560	150	514	18.0	4	3	1400	400/3/50	11	850x970x1950	180
PRO B4900 200 VT4	4116024561	200	514	18.0	4	3	1400	400/3/50	11	850x970x2050	185
PRO B5900B 200 VT5,5	4116024563	200	653	22.9	5,5	4	1400	400/3/50	11	850x970x2050	205
PRO B5900B 270 VT5,5	4116017006	270	653	22.9	5,5	4	1400	400/3/50	11	850x970x2100	210
PRO B6000 270 VT7,5	4116017001	270	827	28.9	7,5	5,5	1400	400/3/50	11	850x970x2100	242
PRO B7000 270 VT10	4116017002	270	1210	42.4	10	7,5	1300	400/3/50	11	850x970x2100	261

* Single phase run off a 16 Amp supply



PRO A39B 150 VM3
3 hp, 150 litres, vertical



Slow speed, lower noise



Optimal cooling for increased reliability



Minimal footprint



PRO B7000 270 VT10
10 hp, 270 litres, vertical



Large condensate drain



Two stage belt driven compressors

PRO high flow BV

An extremely powerful compressor which has been created for the largest of air demands

Applications

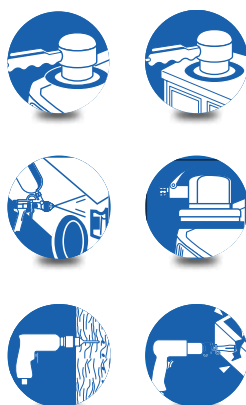

Complete

Electrical control panel with star delta starter as standard

Robust and reliable

Heavy duty two stage, four cylinder pumps



PRO BV8900 900 FT20
20 hp, 900 litres

Performance

Big compressed air volume/flow

Model	Part No	L	L/min	CFM	HP	KW	RPM	Voltage	Bar	L x W x H (mm)	kg
PRO BV8900 900 FT15 YD	4116023343	900	2016	70.6	15	11	800	400/3/50 YD	11	2430x930x1170	535
PRO BV8900 900 FT20 YD	4116021614	900	2400	84.0	20	15	950	400/3/50 YD	11	2430x930x1170	584



Two stage belt driven compressors

PRO high flow tandem

A modular solution. Never without compressed air.

Applications

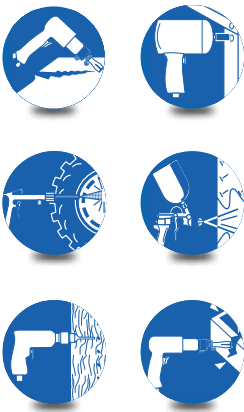

Performance
Proven and well established technology

Flexible
Double pump



PRO B6000 500 T7,5
7,5 + 7,5 hp, 500 litres, tandem

Long-lasting
Strong components

Model	Part No	L	L/min	CFM	HP	KW	RPM	Voltage	Bar	L x W x H (mm)	kg
PRO A39B 270 FM3 TANDEM	4116024868	270	786	27.6	3+3	2,2+2,2	1050	230/1/50	10	1510x470x1030	153
PRO B4900 270 T4	4116023822	270	1028	36.0	4+4	3+3	1400	400/3/50	11	1520x600x1250	243
PRO B4900 500 T4	4116019643	500	1028	36.0	4+4	3+3	1400	400/3/50	11	2030x670x1300	304
PRO B5900 500 T5,5	4116019884	500	1306	45.7	5,5+5,5	4+4	1400	400/3/50	11	2030x670x1400	323
PRO B6000 500 T7,5	4116020375	500	1654	57.9	7,5+7,5	5,5+5,5	1400	400/3/50	11	2030x670x1400	387
PRO B6000 900 T7,5	4116020203	900	1654	57.9	7,5+7,5	5,5+5,5	1400	400/3/50	11	2070x800x1570	500
PRO B7000 900 T10	4116020810	900	2420	84.7	10+10	7,5+7,5	1400	400/3/50	11	2070 X 800 X 1570	525

* Tandem single phase unit requires a 32amp single phase supply



Two stage high pressure belt driven compressors

15 bar PRO range

Suitable for high pressure applications.

Applications

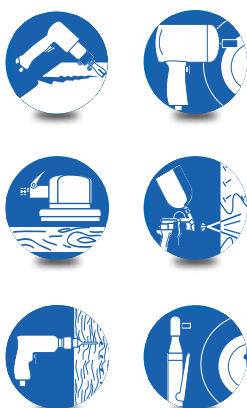

Performance

15 bar operating pressure

Long-lasting

Tested and approved for heavy duty high pressure



PRO B7000 500 FT 10
10 hp, 500 litres, 15 bar

Safety

High pressure approved vessel

Model	Part Code	L	L/min	CFM	HP	KW	RPM	Voltage	Bar	L x W x H (mm)	kg
PRO B6000 500 FT7,5 15 bar	4116020249	500	570	20.0	7,5	5,5	1000	400/3/50 YD	15	2030x670x1400	290
PRO B7000 500 FT10 15 bar	4116020860	500	930	32.6	10	7,5	1000	400/3/50 YD	15	2030x670x1400	305



Two stage high pressure belt driven compressors

Baseplate compressors

Small and compact. The range has been designed and released for those with less space or building their own installation with a separate air vessel.

Applications

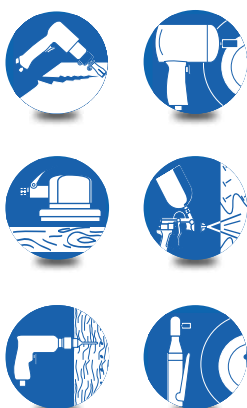

Performance

Known and proven technology

Comfort

Small and compact design



B7000/BF10
10 hp

Connectivity

Easy installation and connection to your network or installation

Model	Part No	L/min	CFM	HP	KW	RPM	Voltage	Bar	L x W x H (mm)	kg
B5900B BF5,5	4116000133	653	22.9	5,5	4	1400	400/3/50	11	1100 x 590 x 800	90
B6000 BF7,5	4116000103	827	28.9	7,5	5,5	1400	400/3/50	11	1100 x 590 x 800	120
B7000 BF10	4116000013	1210	42.4	10	7,5	1300	400/3/50	11	1100 x 640 x 800	135
B8900 BF15	4116000018	2013	70.5	15	11	800	400/3/50 YD	11	1600 x 720 x 1000	338
B8900 BF20	4116000016	2400	84.0	20	15	950	400/3/50 YD	11	1600 x 720 x 1000	350

The pressure switch and the starter units are not included.
The non return valve solenoid is 110 Volt.



Two stage belt driven compressors

PRO Cast-Iron

With pump unit made entirely of cast iron.

Reliable and robust, are built with high quality components.

Applications

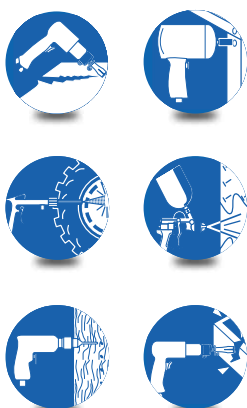

Robust
Cast iron
components

Reliable
Low speed,
low wear and tear



Safety
Metal belt guard

PRO CA2 500 FT10
10 hp, 500 litres, 11 bar

Model	Part No	L	L/min	CFM	HP	KW	RPM	Voltage	Bar	L x W x H (mm)	kg
PRO CA1 270 FT5,5	4116025181	270	530	18,7	5,5	4	688	400/3/50	11	1500x530x1210	214
PRO CA1 500 FT5,5	4116025186	500	530	18,7	5,5	4	688	400/3/50	11	1920x600x1340	303
PRO CA1 270 FT7,5	4116025182	270	699	24,7	7,5	5,5	908	400/3/50	11	1500x530x1210	239
PRO CA1 500 FT7,5	4116025183	500	699	24,7	7,5	5,5	908	400/3/50	11	1920x600x1340	328
PRO CA2 500 FT10 YD	4116025246	500	1056	37,3	10	7,5	685	400/3/50 YD	11	1920x600x1340	358
PRO CA2 500 FT10	4116025185	500	1056	37,3	10	7,5	685	400/3/50	11	1920x600x1340	358
PRO CA2 500 FT10 YD	4116025190	500	1056	37,3	10	7,5	685	400/3/50 YD	11	1920x600x1340	358
PRO T CA1 500 FT7,5	4116025184	500	1399	49,5	7,5+7,5	5,5+5,5	908	400/3/50	11	1920x600x1340	488



Information

QR

During 2019 all direct driven and belt driven ABAC compressors will have a QR code on the air receiver. Scan this QR code with your smart phone / tablet and go directly to our E-service website page.



Belt driven QR code

Scan the QR code with your phone to see the links to videos and documentation

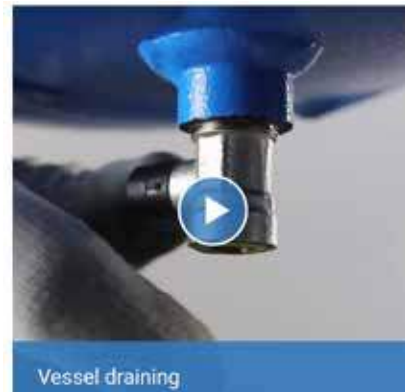

Videos

Step by step videos to help you get the most out of your new ABAC piston compressor from initial setup start-up to weekly maintenance



HOSE REELS AND AIR TOOL KITS

Accessories to go with your ABAC piston compressor





Accessories

Hose reel

In a box all the kit necessary to mount on all belt-driven compressors with tanks capacity 27 to 270 litres, one winder provided with a rubber hose which is either 5 or 10 metres.



Order
No more loose hose
on the ground



Flexible
Suitable for tanks
from 27 to 270 litres

Easy
To mount
and install

Model	Part No	Hose length mt	Type of joint	L x W x H (mm)	kg
Hose reel + 5 mt hose with snap couplings	2901325170	5	snap coupling	250x235x160	1.3
Hose reel + 10 mt hose with snap couplings	2901325171	10	snap coupling	250x235x161	1.3



Accessories

Air Tool Kits

In a box all the kit necessary to go with your ABAC compressor.

5 Piece Air Tool Kit

- Tyre inflator
- Air wash gun
- Spiral hose (5 m)
- Air blow gun
- Gravity fed spray gun 1.2 L capacity



34 Piece Air Tool Kit

- Air hammer with 3 different chisel blades
- 3/8" Air ratchet wrench
- 1/2" Air impact wrench and sockets
- 1/4" Die grinder with grinding points
- Quick release coupling and adaptors

71 Piece Air Tool Kit

- Air hammer with 3 different chisel blades
- 3/8" Air ratchet wrench
- 1/2" Air impact wrench and sockets
- 1/4" Die grinder with grinding points
- Air blow guns
- Quick release coupling and adaptors



Model	Part No	kg	
Kit 5 pieces	8973005547	2.1	
Kit 34 pieces	8973005156	8.2	
Kit 71 pieces	8973005055	8.7	



SILENCED

*Silenced, flexible and user friendly in operation
Strong and durable designs*





Silenced one stage belt driven compressors

S A29B and S A39B

This range of products has a strong focus on the combination of noise reduction and moveability.

Applications

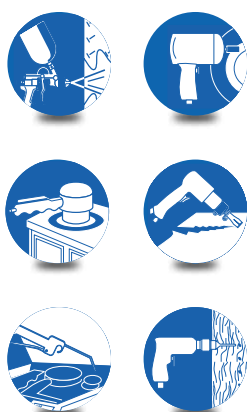

Comfort

Noise reducing cover

User-friendly

Easy open closing for maintenance



S A39B 200 FT3
3 hp, 200 litres, silenced

Model	Part No	L	L/min	CFM	HP	KW	RPM	Voltage	Bar	SPL dB(A)	LwA dB(A)	L x W x H (mm)	kg
S A29B 90 CM2	4116007370	90	255	9	2	1,5	1075	230/50/1*	10	69	89	1010 x 415 x 980	59
S A29B 90 FM2	4116007371	90	255	9	2	1,5	1075	230/50/1*	10	69	89	1010 x 415 x 980	59
S A29B 150 CM2	4116007372	150	255	9	2	1,5	1075	230/50/1*	10	69	89	1375 x 420 x 1030	90
S A29B 150 FM2	4116007373	150	255	9	2	1,5	1075	230/50/1*	10	69	89	1375 x 420 x 1030	90

* Single phase run off a 13 Amp supply



S A29B 90 CM2
2 hp, 90 litres, silenced



Small hood with minimal width



Stability and moveability remains



S A29B 90 CM2
2 hp, 90 litres, cover opened



Easy to open and close with locating peg and hinge for easy maintenance access

Model	Part No	L	L/min	CFM	HP	KW	RMP	Voltage	Bar	SPL dB(A)	LwA dB(A)	L x W x H (mm)	kg
S A39B 150 FM3	4116007362	150	393	13.9	3	2,2	1050	230/50/1**	10	71	91	1375 x 420 x 1030	90
S A39B 150 FT3	4116007363	150	393	13.9	3	2,2	1050	400/3/50	10	71	91	1375 x 420 x 1030	90
S A39B 200 FM3	4116007364	200	393	13.9	3	2,2	1050	230/50/1**	10	71	91	1500 x 470 x 1190	94
S A39B 200 FT3	4116007365	200	393	13.9	3	2,2	1050	400/3/50	10	71	91	1500 x 470 x 1190	94

** Single phase run off a 16 Amp supply



Silenced two stage belt driven compressors

S B4900, B5900B and B6000

High performance pump and nicely designed silencing.

Applications

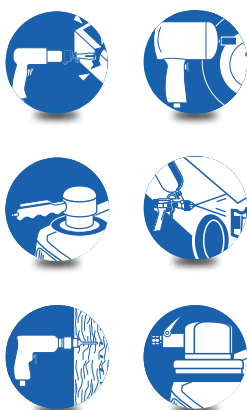

Innovative design

Hood with foam to reduce noise

User-friendly

Hour counter to indicate running hours



S B5900B 270 FT5,5
5,5 hp, 270 litres, silenced

Comfort

Easy oil check window

Model	Part No	L	L/min	CFM	HP	KW	RPM	Voltage	Bar	SPL dB(A)	LwA dB(A)	L x W x H (mm)	kg
S B4900 270 FT4	4116007332	270	425	15	4	3	1200	400/3/50	11	69	89	1500x1200x660	154
S B5900B 270 FT5,5	4116007333	270	525	18.5	5,5	4	1100	400/3/50	11	71	91	1500x1200x660	177
S B5900B 270 VT5,5	4116007335	270	525	18.5	5,5	4	1100	400/3/50	11	71	91	1060x700x1900	230
S B5900B 500 FT5,5	4116007334	500	525	18.5	5,5	4	1100	400/3/50	11	71	91	1900x700x1320	229
S B6000 270 FT7,5	4116007336	270	660	23.3	7,5	5,5	1150	400/3/50	11	77	97	1500x1200x660	187
S B6000 270 VT7,5	4116007338	270	660	23.3	7,5	5,5	1150	400/3/50	11	77	97	1060x700x1900	250
S B6000 500 FT7,5	4116007337	500	660	23.3	7,5	5,5	1150	400/3/50	11	77	97	1900x700x1320	270

VT = Type vertical



S B5900B 270 FT5,5
5,5 hp, 270 litres, silenced



Strong and proven technology inside



Well designed cooling flows



Standard hour counter



S B6000 500 FT7,5
7,5 hp, 500 litres, silenced



Easy to check oil before starting up



Silent one and two stage belt driven compressors

Basemounted Full Silent

Maximum noise reduction in combination with easy and straightforward use.

Applications

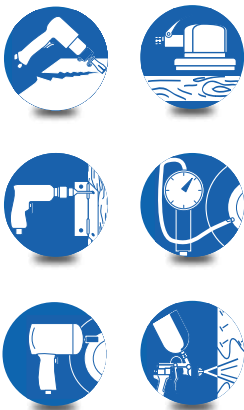

User-friendly
Central control panel

Comfort
Metal canopy with foam to reduce noise



A29B LN M2
2 hp, 27 litres, silenced

Easy maintenance
Simple access to all components

Flexible
Integrated tank with vibration pads

Model	Part No	L	L/min	CFM	HP	KW	RPM	Voltage	Bar	SPL dB(A)	LwA dB(A)	L x W x H (mm)	kg
A29B LN M2	4116074036	27	255	9	2	1,5	1075	230/50/1	10	61	81	780 x 470 x 960	86
A29B LN T2	4116074037	27	255	9	2	1,5	1075	400/3/50	10	61	81	780 x 470 x 960	86
A29B LN M3	4116074041	27	320	11.3	3	2,2	1350	230/50/1	10	62	82	780 x 470 x 960	87
A29B LN T3	4116074039	27	320	11.3	3	2,2	1350	400/3/50	10	62	82	780 x 470 x 960	87

* Single phase run off a 13 Amp supply



B7000 LN T10
10 hp, silenced



User-friendly central control panel



Easy access and maintenance



Cooling with extra electric fan (on 7,5 and 10hp)

Model	Part No	L	L/min	CFM	HP	KW	RPM	Voltage	Bar	SPL dB(A)	LwA dB(A)	L x W x H (mm)	kg
B4900 LN T4	4116007011	0	425	15	4	3	1200	400/3/50	11	65	85	945x760x960	170
B5900 LN T5,5	4116007012	0	570	20.1	5,5	4	1200	400/3/50	11	67	87	945x760x960	177
B6000 LN T7,5	4116007015	0	660	23.3	7,5	5,5	1150	400/3/50	11	69	89	1270x780x890	234
B7000 LN T10 YD	4116007018	0	1050	37.0	10	7,5	1150	400/3/50 YD	11	71	91	1270x780x890	253



Silent two stage belt driven compressors

Tankmounted Full Silent

High duty two stage piston compressors for every workshop. A full 'all in one' design.

Comfort
Noise reducing
metal cover with foam

User-friendly
Clear and nicely
grouped control panel



B5900 LN 270 5,5
5,5 hp, 270 litres, silenced

Applications

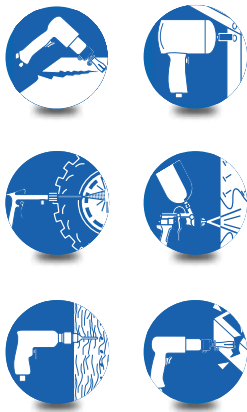

Model	Part No	L	L/min	CFM	HP	KW	RPM	Voltage	Bar	SPL dB(A)	LwA dB(A)	Lx W x H (mm)	kg
B4900 LN 270 4	4116007010	270	425	15	4	3	1200	400/3/50	11	65	85	1600x630x1530	238
B5900 LN 270 5,5	4116007062	270	570	20.1	5,5	4	1200	400/3/50	11	67	87	1600x630x1530	248
B5900 LN 500 5,5	4116007003	500	570	20.1	5,5	4	1200	400/3/50	11	67	87	2020x1000x1600	302
B6000 LN 500 7,5	4116007005	500	660	23.3	7,5	5,5	1150	400/3/50	11	68	88	2020x1000x1600	404
B7000 LN 500 10YD	4116007008	500	1050	37	10	7,5	1150	400/3/50 YD	11	69	89	2020x1000x1600	448



B7000 LN 500 T10 DRY
10 hp, 500 litres, silenced + dryer



All in one: integrated dryer



Easy access and maintenance



Cooling with extra electric fan (on 7,5 and 10hp)

Model	Part No	L	L/min	CFM	HP	KW	RPM	Voltage	Bar	SPL dB(A)	LwA dB(A)	Lx W x H (mm)	kg
B5900 LN 500 T 5,5 DRY	4116007040	500	570	20.1	5,5	4	1200	400/3/50	11	67	87	2020x1000x1600	302
B6000 LN 500 T 7,5 DRY	4116007042	500	660	23.3	7,5	5,5	1150	400/3/50	11	69	89	2020x1000x1600	404
B7000 LN 500 T 10 DRY	4116007044	500	1050	37	10	7,5	1150	400/3/50	11	71	91	2020x1000x1600	442
B7000 LN 500 T 10 DRY	4116007045	500	1050	37	10	7,5	1150	400/3/50 YD	11	71	91	2020x1000x1600	448



TRADE Line

*Personal onsite air specially designed for use
where safety regulation demand the use
of lower voltage equipment*





Direct and Belt Driven 110V Compressors

TRADE Line Range

110 volt compressors to meet on site safety regulation demands.

Applications

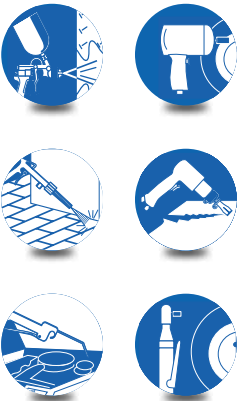

Safety
No oil spillage

Comfort
Rubber grip for more control



User-friendly
Reliable and easy to switch ON / OFF

POLE POSITION 020P
2 hp, 24 litres, oil free

Maneuverable
Bigger wheels for better handling

Model	Part No	L	L/min	CFM	HP	KW	RPM	Voltage	Bar	dB(A)	L x W x H (mm)	kg
START ROLLAGE O20P	1121020318	9	230	8.1	2	1.5	2850	110/50/1	8	75	455x475x500	21
POLE POSITION O20P	1121210973	24	230	8.1	2	1.5	2850	110/50/1	8	75	530x210x540	15
PRO A29B 50 CM2	4116025300	50	255	8.9	1.5	1.2	1075	110/50/1	10	93	1375 x 420 x 950	87

All models need to be run from a minimum 3.5KVA transformer - recommended 5KVA





START ROLLCAGE O20P
2 hp, 9 litres, oil free



Slow speed, low temperature, low noise



Safe and strong grip to move unit



PRO A29B 50 CM2
2 hp, 50 litres



Big pressure gauges for easy reading



Safe and strong cover



cleanAIR

*Extremely low noise levels
With dryer for dry air absorption
Epoxy paint
Very small dimensions
Meets conformity of HTM 2022 on models
fitted with dryer*





The constructive technology

- Oil-free Compression that ensures clean and oil-free air
- Pump directly driven by motor with minimal transmission losses and optimal performance
- Electric motor with automatic thermal protection for safe operation
- High-capacity fan for optimum cooling

Open-frame versions with and without dryer

cleanAIR and cleanAIR T

Top quality air for intensive use with 50% duty rating. Air adsorption dryer for moisture removal. A full 'all in one' design.



CLR 15
1,5 hp, 2 cylinders



CLR 25
2,5 hp, 4 cylinders



CLR 20
2,0 hp, 2 cylinders

Oilfree

Tank internally treated with epoxy paint

CLR 15/50
1,5 hp, 50 litres



Silent fan cooling and high efficiency

Conforms with
HTM 2022

Dryer

-40 degree Celsius
dew point dessicant/
adsorption dryer



CLR 15/25 T
1,5 hp, 25 litres, dryer



CLR 25/50 T
2,5 hp, 50 litres, dryer



Dryer and adsorption
(only on versions CLEAN-AIR T)
To conform with HTM 2022

Model	Part No	N. unit	Air displacement		FAD @ 5bar		Motor		RPM	Voltage	Tank	Press.	Noise level	Dimesions	Weight
			I/min	CFM	I/min	CFM	HP	kW							
			Volt/Hz	Lt	BAR	dB(A)	W x D x H /mm	Kg							
CLR 15/25	4116092271	1-2	240	8.5	125	4.4	1,5	1,1	1400	230/50/1	25	8	70,8	470x430x665	31
CLR 15/50	4116092275	1-2	240	8.5	125	4.4	1,5	1,1	1400	230/50/1	50	8	70,8	450x470x850	36
CLR 20/25	4116092273	2-3	350	12.3	155	5.5	2,0	1,5	1400	230/50/1	25	8	73,6	470x470x700	49
CLR 20/50	4116092277	2-3	350	12.3	155	5.5	2,0	1,5	1400	230/50/1	50	8	73,6	450x470x850	40
CLR 25/50	4116092293	4-5	480	17	240	8.5	2,5	2	1400	230/50/1	50	8	77	640x470x890	52

With dryer

Model	Part No	N. unit	Air displacement		FAD @ 5bar		Motor		RPM	Voltage	Tank	Press.	Noise level	Dimesions	Weight
			I/min	CFM	I/min	CFM	HP	kW							
			Volt/Hz	Lt	BAR	dB(A)	W x D x H /mm	Kg							
CLR 15/25 T	4116092272	1-2	240	8.5	125	4.4	1,5	1,1	1400	230/50/1	25	8	70,8	525x470x665	43
CLR 15/50 T	4116092276	1-2	240	8.5	125	4.4	1,5	1,1	1400	230/50/1	50	8	70,8	600x470x850	47
CLR 20/25 T	4116092274	2-3	350	12.3	155	5.5	2,0	1,5	1400	230/50/1	25	8	73,6	550x470x700	50
CLR 20/50 T	4116092278	2-3	350	12.3	155	5.5	2,0	1,5	1400	230/50/1	50	8	73,6	600x470x850	54
CLR 25/50 T	4116092294	4-5	480	17	240	8.5	2,5	2	1400	230/50/1	50	8	77	640x470x890	60



Versions with silencing box

cleanAIR S cleanAIR S T

Noise reduction by up to 10 decibels with cutting edge design to ensure effective cooling, low operating temperatures and long service life.

Applications



Comfort
Soundproof cabinet for even quieter operation



CLR 15/30 S
1,5 hp, 30 litres, soundproofed

Model	Part No	N. unit	Air displacement		FAD @ 5bar		Motor		RPM	Voltage	Tank	Press.	Noise level	Dimensions	Weight
			l/min	CFM	l/min	CFM	HP	kW		Volt/Hz	Lt	BAR	dB(A)		
CLR 15/30 S	4116092283	1-2	240	8.5	125	4.4	1,5	1,1	1400	230/50/1	30	8	64,1	650x440x760	68
CLR 20/30 S	4116092285	2-3	350	12.3	155	5.5	2,0	1,5	1400	230/50/1	30	8	64,1	650x440x760	72



Dryer
 -40 degree Celsius dew point
 dessicant/ adsorption dryer



Pump unit totally oil free



Pump unit mounted on anti-vibration devices



Cyclone separator as standard (only version with dryer)

CLR 20/30 ST

2,0 hp, 30 litres, soundproofed, dryer

Model	Part No	N. unit	Air displacement		FAD @ 5bar		Motor		RPM	Voltage	Tank	Press.	Noise level	Dimesions	Weight
			l/min	CFM	l/min	CFM	HP	kW							
			Volt/Hz	Lt	BAR	dB(A)	W x D x H /mm	Kg							
CLR 15/30 ST	4116092284	1-2	240	8.5	125	4.4	1,5	1,1	1400	230/50/1	30	8	64,1	730x440x760	75
CLR 20/30 S T	4116092286	2-3	350	12.3	155	5.5	2,0	1,5	1400	230/50/1	30	8	64,1	730x440x760	79



engineAIR

*Ease of use and transport
Extremely low noise levels*





Wheeled compressors with engine

Able to supply compressed air to multiple tools simultaneously and continuously, even for long periods of use. Totally independent from an electrical power source, they provide amounts of compressed air in all circumstances.

Safe
Sturdy metal grid that protects all moving parts



Device that reduces the engine speed when idle



Honda, unleaded petrol internal combustion engine

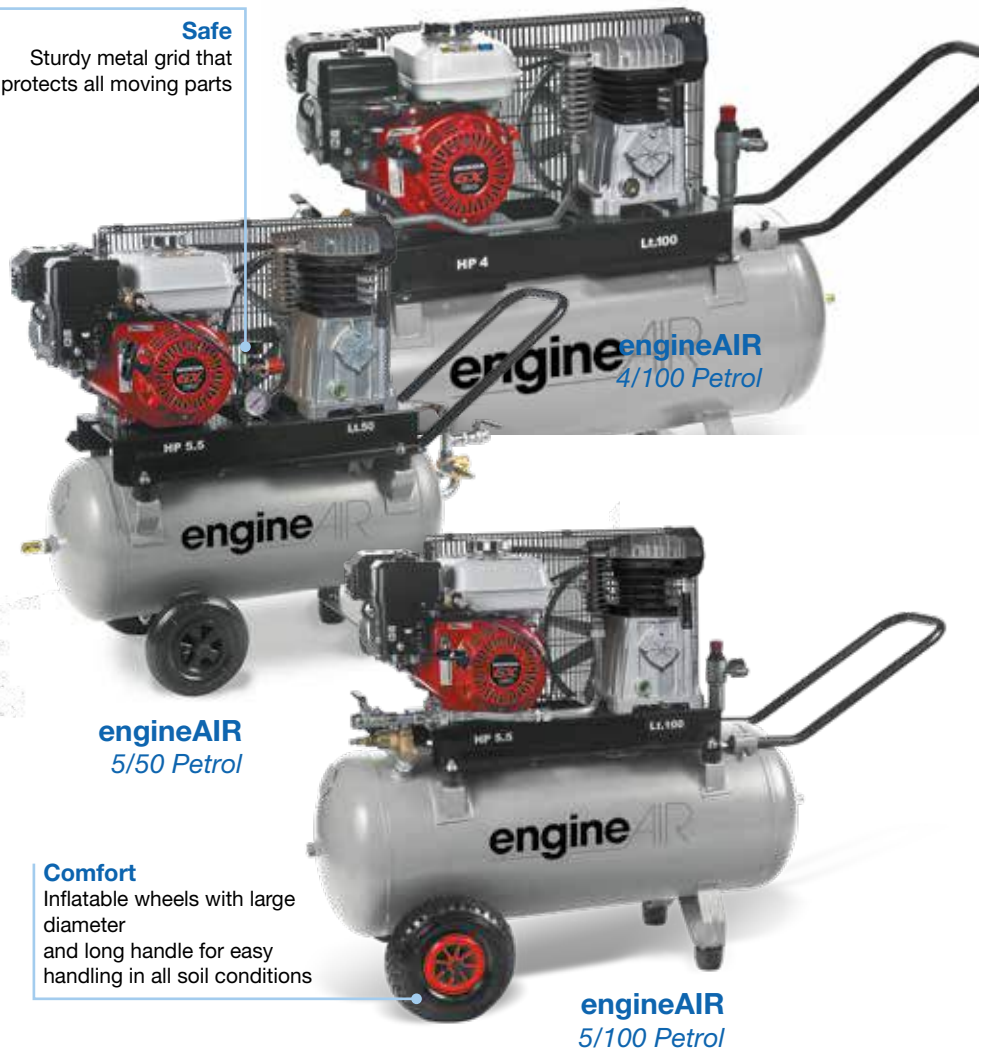

engineAIR
5/50 Petrol

engineAIR
5/100 Petrol

Comfort
Inflatable wheels with large diameter and long handle for easy handling in all soil conditions

Model	Part No	Pump	LT	L/min	CFM	HP	KW	RPM	bar	dB(A)	Lw(A)	mm	Kg
engineAIR 4/100 Petrol*	4116002086	A29B	100	281	9.9	3,5	2,6	1380	10	72	96	1090x420x1030	71
engineAIR 5/50 Petrol*	4116002087	A39B	50	348	12.3	4,8	3,6	1060	10	72	96	1000x410x870	73
engineAIR 5/100 Petrol*	4116002088	A39B	100	348	12.3	4,8	3,6	1060	10	72	96	1090x420x1030	94
engineAIR 5/200 Petrol*	4116002089	A39B	200	348	12.3	4,8	3,6	1060	10	72	96	1500x450x1100	120

* Engine fitted with speed regulation

Compressors with engine and double tank

VERSIONS WITH PETROL ENGINE

Metal roll bar for full protection. Easy to carry and handle

Ergonomic handle and large inflatable wheels for easy handling on difficult soil

Easy to install
Pre-installed: simply connect to a tank and you're ready.

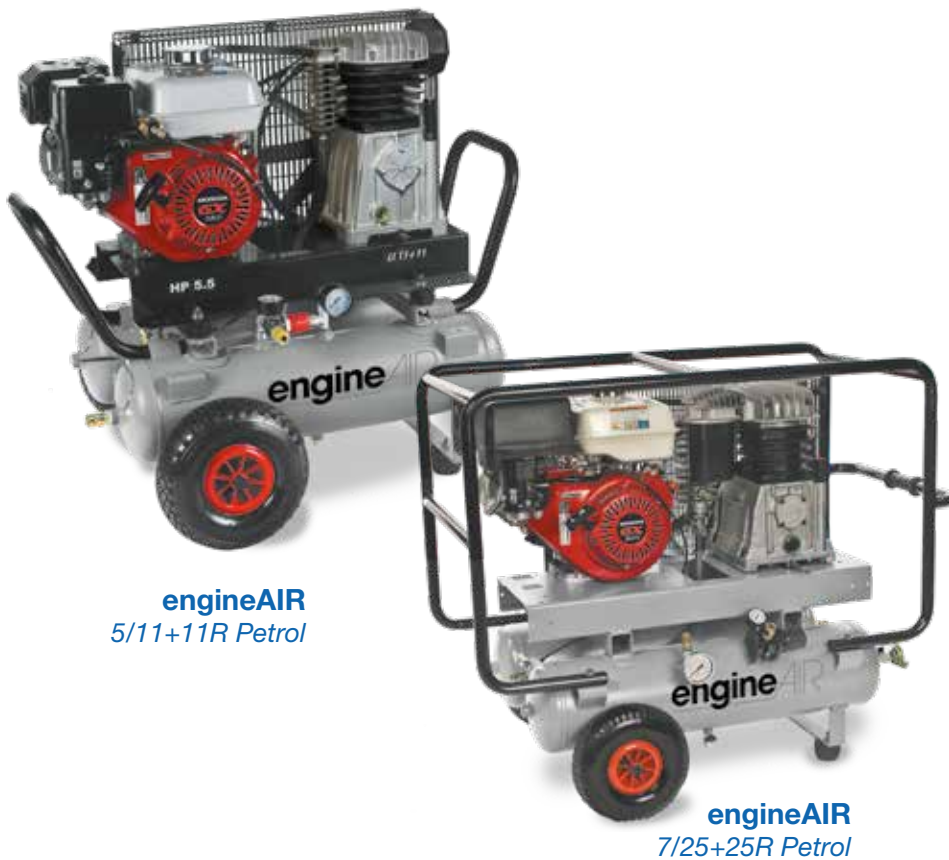

All components are fully protected by the tubular steel frame.



Two direct outputs and a set for a large number of uses.

Moel	Part No	Pump	LT	l/min CFM	HP	KW	RPM	bar	dB(A) Lw(A)	mm	Kg
engineAIR 5/11+11 Petrol*	4116002090	A39B	11+11C	348 12,3	4,8	3,6	1060	10	72 96	1070x770x1040	70
engineAIR 5/11+11R Petrol*	4116002091	A39B	11+11C	348 20,1	4,8	3,6	1060	10	72 96	1070x770x1040	70
engineAIR 7/25+25R Petrol*	4116022690	B5900B	25+25C	570 20,1	7,1	5,3	1200	10	72 96	1235x835x1100	143

* Engine fitted with speed regulation



Compressors with engines

Lombardini Diesel engine, low fuel consumption, electric start



Honda petrol engine, low noise level, highly reliable, electric start

Kit for exhaust pipe elongation for use indoor or in enclosed vehicles*.



Group/motor base mounted on 4 rubber anti-vibration dampers for reduced vibration, noise reduction and longer service life (only Diesel models).



engineAIR
7/270 Diesel

Easy maintenance LED control panel with battery charge indicator and oil overpressure



engineAIR
7/270 Petrol

Model	Part No	Fuel	Ignition. Electric**	Pump	LT	L/min	CFM	HP	KW	RPM	bar	dB(A)	Lw(A)	mm	Kg
EngineAir 7/270 Petrol	4116022691	Petrol	✓	B5900B	270F	476	16.8	7,1	5,3	1000	14	80	104	1395x745x1500	223
EngineAir 11/270 Petrol	4116022692	Petrol	✓	B6000	270F	741	26.2	10,7	8,2	1300	14	80	104	1395x745x1500	235
EngineAir 8/270 Diesel	4116022693	Diesel	✓	B6000	270F	630	22.2	7,5	5,5	1100	14	86	110	1395x745x1500	239
EngineAir 11/270 Diesel	4116022694	Diesel	✓	B7000	270F	990	35	10,9	8,2	1065	14	86	110	1395x745x1500	258

* Exhaust extension Kit for indoor use or in enclosed vehicles.

For diesel engines code 8973000423 price see spare parts price list.

For petrol engines over 7 HP code 8973000422 price see spare parts price list.

** ELECTRIC IGNITION DOES NOT INCLUDE BATTERY AND CONNECTION CABLES.

Recoil start also fitted if no 12V battery supply available.

Compressors with internal combustion engine on base and power generator

engineAIR
11 Diesel



Model	Part No	Fuel	Ignition. Electric**	Pump	LT	L/min	CFM	HP	KW	RPM	bar	dB(A)	Lw(A)	mm	Kg
EngineAIR 4 Petrol*	4116002092	Petrol	x	A29B	Base mounted	281	9.9	3,5	2,6	1380	10	72	95,7	860x490x750	57
EngineAIR 5 Petrol*	4116002093	Petrol	x	A29B	Base mounted	348	12.3	4,8	3,6	1060	10	72	95,8	860x490x750	63
EngineAIR 7 Petrol*	4116002073	Petrol	✓	B5900B	Base mounted	476	16.8	7,1	5,3	1000	14	80	103,7	1200x685x880	117
EngineAIR 11 Petrol*	4116002074	Petrol	✓	B6000	Base mounted	741	26.2	10,7	8,2	1300	14	80	104,4	1200x685x880	128
EngineAIR 12 Petrol*	4116002082	Petrol	✓	B7000	Base mounted	893	31.5	11,7	8,8	960	11	80	104,4	1200x685x880	142
EngineAIR 8 Diesel	4116002075	Diesel	✓	B6000	Base mounted	630	22.2	7,5	5,5	1100	14	86	110,2	1200x685x880	142
EngineAIR 11 Diesel	4116002076	Diesel	✓	B7000	Base mounted	990	35	10,9	8,2	1065	14	86	109,8	1200x685x880	151
EngineAIR 12 Diesel	4116002083	Diesel	✓	B7000	Base mounted	1050	37	12	9	1100	11	86	109,8	1200x685x880	154

* Engine fitted with speed regulation



BlengineAIR 11/270
Diesel 2,2 KvA



BlengineAIR 8
Diesel 2,2 KvA



The two-in-one solution with smaller footprint. One powerful diesel engine able to provide both compressed air and electricity. Pumping unit with high efficiency and 230 volt power generator.

Model	Part No	Fuel	Ignition. Electric**	Pump	LT	L/min	CFM	HP	KW	RPM	bar	dB(A)	Lw(A)	mm	Kg
BI EngineAIR 8 Diesel 2,2 KvA	4116002077	Diesel	✓	B4900	Base mounted	408	14.4	7,5	5,5	1150	14	86	110,2	1200x685x880	157
BI EngineAIR 11 Diesel 2,2 KvA	4116002078	Diesel	✓	B6000	Base mounted	570	20.1	10,9	8,2	1000	14	86	109,8	1200x685x880	184
BI EngineAIR 12 Diesel 3 KvA	4116002084	Diesel	✓	B7000	Base mounted	1000	35.3	12	9	1050	11	86	109,8	1200x685x880	201
BI EngineAIR 8/270 Diesel 2,2 KvA	4116022695	Diesel	✓	B4900	270F	408	14.4	7,5	5,5	1150	14	86	110	1395x745x1500	265
BI EngineAIR 11/270 Diesel 2,2 KvA	4116022696	Diesel	✓	B6000	270F	570	20.1	10,9	8,2	1000	14	86	110	1395x745x1500	270

* Exhaust extension Kit for indoor use or in enclosed vehicles.

For diesel engines code 8973000423 price see spare parts price list.

For petrol engines over 7 HP code 8973000422 price see spare parts price list.

** ELECTRIC IGNITION DOES NOT INCLUDE BATTERY AND CONNECTION CABLES

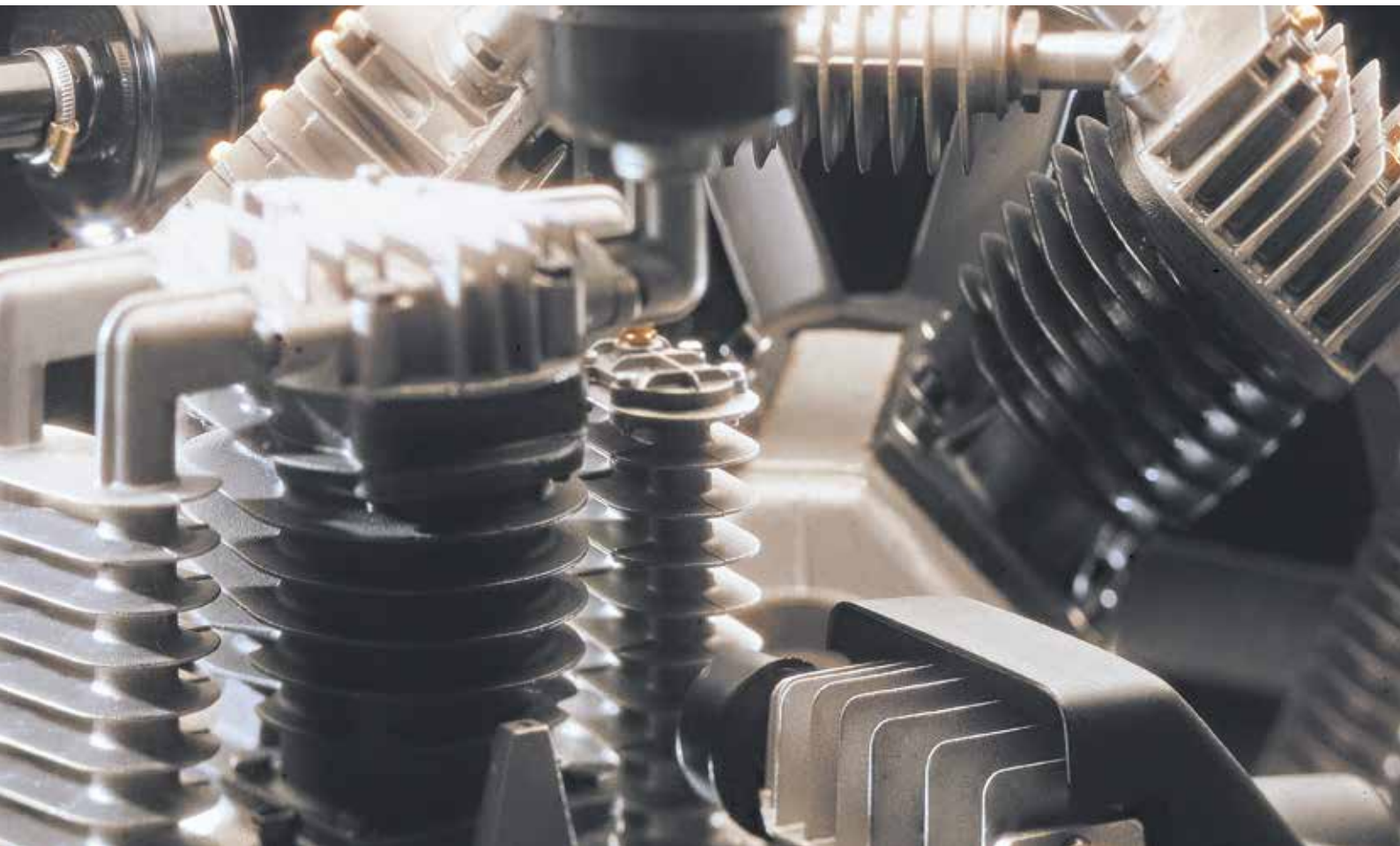

PUMPS

Reliable
Long-lasting
Low operating temperatures
Efficiency



Specifications

- Cylinders and heads in die-cast aluminium.
- Special stainless steel valves for higher output.
- Forced cooling and piped on the hottest part.

Oil free Direct Driven compressors electric driven unit

Characterised by the absence of lubricating oil inside the pumping unit. Moving parts shall take special constructive solutions and materials with low friction coefficient and high resistance to wear and tear for which do not require lubrication during operation.



Model	Part No	Cylinders	Stages	L/min	CFM	HP	KW	RPM	Volt/Hz	bar
O10P	1122010330	1	1	150	5.3	1	0,7	1450	230/50	8
O20P	1122010328	1	1	205	7.2	1,5	1,1	2850	230/50	8

Code	Pump	A	D	E	P
1122010330	O10P	312	190	400	1/4"
1122010328	O20P	312	190	400	1/4"

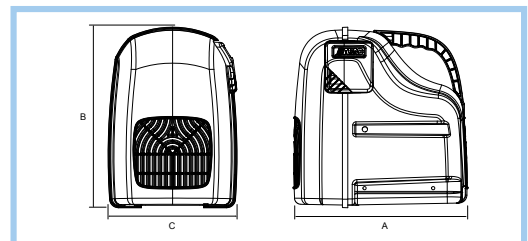

Specifications

- Low current consumption.
- Single phase electric motor with overheating thermal protection.
- Sturdy, lightweight and compact.
- Final testing of all the pieces.

Lubricated Direct Driven compressors electric units

A special lubrication system provides oil circulation within the pumping unit, providing an optimal lubrication of moving mechanical parts.



L20



L25P



L30P



V30

Model	Part No	Cylinder	Stages	L/min	CFM	HP	KW	RPM	Volt/Hz	bar
L20	1129100245	1	1	220	7.8	2	1,5	2850	230/50	8
L25	1129100338	1	1	270	9.5	2,5	1,9	2850	230/50	10
L30	1129100409	1	1	159	5.6	3	2,2	2850	230/50	10
V30	1123020718	2	1	159	5.6	3	2,2	1450	230/50	10

Code	Pump	A	B	D	E	G	L	N	P
1129100245	L20	285		170	355		110	M6	3/8"
1129100338	L25	263		166	375	139	64	9	3/8"
1129100409	L30	264		166	375	139	64	9	1/2"
1123020718	V30		355	457	485	130	156	9	1/2"

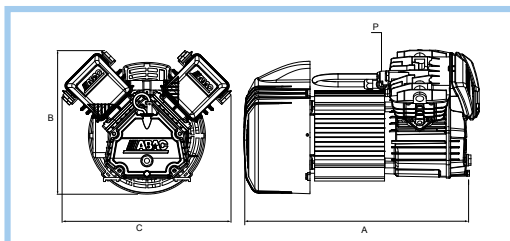
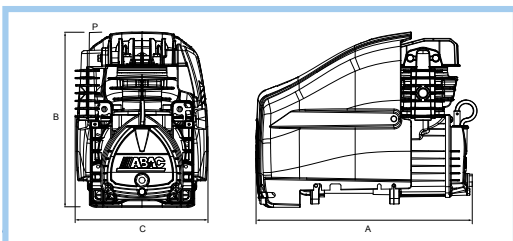

Specifications

- Die-cast aluminium Heads with large cooling fins for better cooling.
- Larger oil sump for better lubrication.
- Special valve plates with higher resistance to wear and tear.

Single stage belt driven compressor units

Characterized by pumping groups with cylinders and heads in die-cast aluminium or cast iron with large cooling fins and end manifolds for more efficient cooling, which improves the volumetric efficiency of the compressor.



B26 / B26B

A29 / A29B

A39 / A39B

Model	Part No	Cylinder	Stages	L/min	CFM	HP	KW	RPM	Volt/Hz	bar
A29	4116090299	2	1	255	9	2	1,5	1075	-	10
A29B	4116090300	2	1	255	9	2	1,5	1075	-	10
				320	11.3	3	2,2	1300	-	10
A39	4116090301	2	1	393	13.9	3	2,2	1050	-	10
A39B	4116090302	2	1	393	13.9	3	2,2	1050	-	10
				486	17.2	4	3	1300	-	10
B26	1123020527	2	1	159	5.6	2	1,5	1240	-	10
B26B	1123020530	2	1	159	5.6	3	2,2	1500	-	10

Code	Pump	A	B	C	D	E	F	G	L	M	N	P
4116090299	A29	300	350	330	187	256	96,5	162	132	77,5	9	3/8"
4116090300	A29B	300	350	330	187	256	96,5	162	132	77,5	9	3/4"
4116090301	A39	362	415	390	189	261	123	156	140	91	8,5	1/2"
4116090302	A39B	362	415	390	189	261	123	156	140	91	8,5	3/4"
1123020527	B26	175	123	65	300	A	10.5	180	245	28.5	1/2"	
1123020530	B26B	175	123	65	300	A	10.5	180	245	28.5	1/2"	

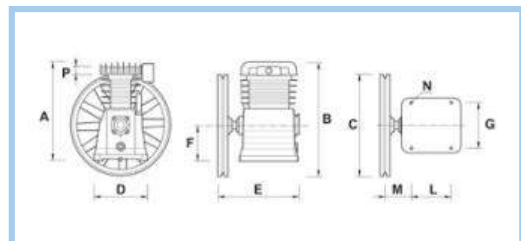
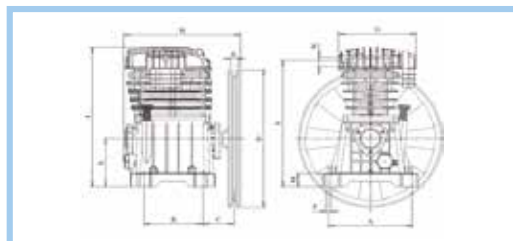

Specifications

- Powerful, quiet and safe.
- Suitable for heavy duty.
- Designed for very high life spans.
- Low power consumption.
- Two stage pumps with intermediate cooling between the two compression stages.

Two-stage belt driven compressor units

The air is compressed in a first stage, cooled and then compressed in a second phase, allowing to reach very high yields of pumping units.



B4900



B5900B



B7000



B6000



BV8900



B7900

Model	Part No	Cylinder	Stages	L/min	CFM	HP	KW	RPM	Volt/Hz	bar
B 4900	4116090007	2	2	514	18.1	4	3	1400	-	11
B 4900B	4116090122	2	5	514	18.1	4	3	1400	-	11
B 5900B	4116090252	2	2	653	23	5,5	4	1400	-	11
B 6000	4116090254	2	2	660	23.3	5,5	4	1100	-	11
				827	29.2	7,5	5,5	1400		
B 7000	4116090261	2	2	1023	36.1	7,5	5,5	1100	-	11
				1210	42.7	10	7,5	1300		
B 7900	4116090253	2	2	950	33.5	7,5	5,5	750	-	11
				1130	39.9	10	7,5	900		
BV 8900	4116090001	4	2	2016	71.2	15	11	800	-	11
				2400	84.8	20	15	950		
				2770	97.8	25	18,5	1100		

Code	Pump	A	B	C	D	E	F	G	L	M	N	P
4116090007	B4900	364	413	350	280	310	126,5	174	146	105	10,5	1"
4116090252	B5900B	405	490	430	320	345	131	190	170	110	10,5	1-1/4"
4116090254	B6000	445	510	430	350	360	150	248	198	112	13	1-1/4"
4116090261	B7000	560	600	430	500	415	175	290	240	122	15	1-1/4"
4116090253	B7900	615	670	430	500	410	160	288	230	110	14	1-1/4"
4116090001	BV8900	670	790	630	780	525	195	350	310	155	15	1"

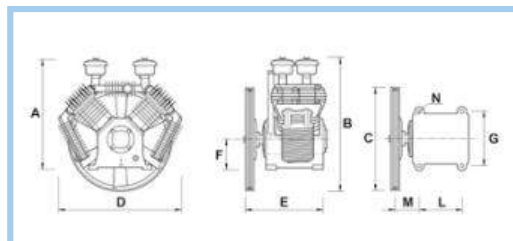
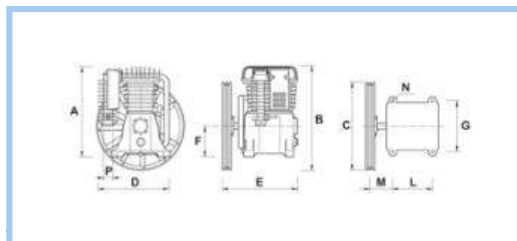



QUALITY AIR SOLUTIONS

Refrigerant Dryers
Adsorption Dryers
Filters
Oil-Water Separators
Accessories



ISO 8573-1 Dust-Water-Oil	Applications
Class 1:4:1	
Class 1:4:2	
Class 2:2:1 Class 2:1:1	

Quality Air

Improve your business' productivity, quality and efficiency

Solutions to transform compressed air generated in high quality air used.

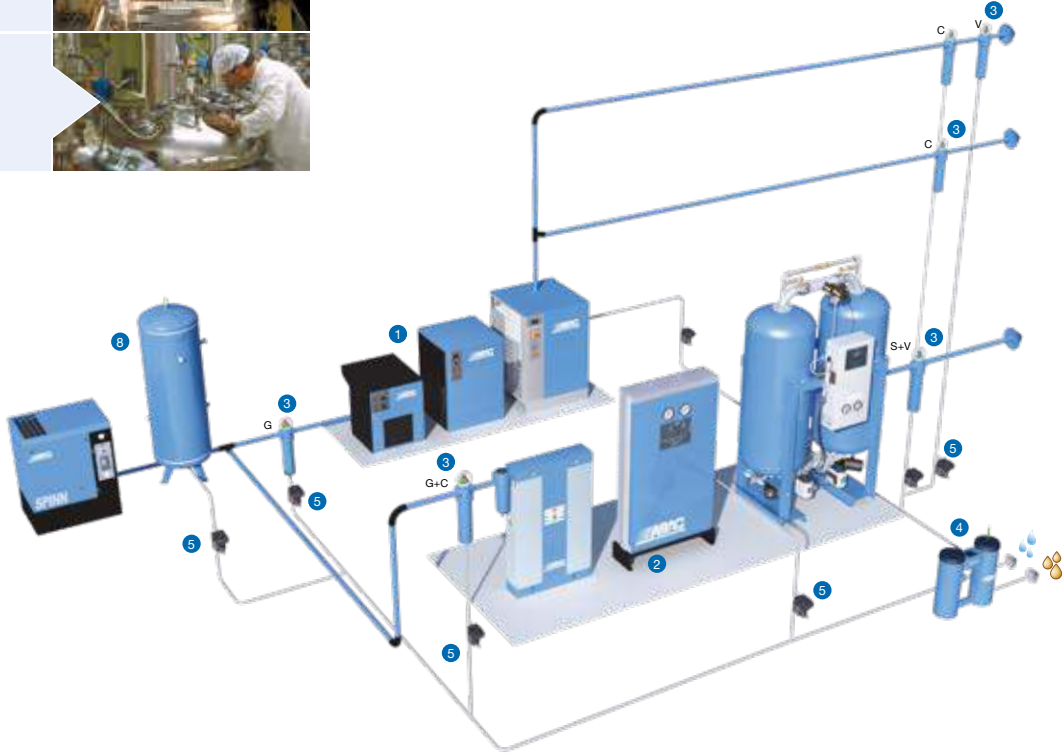

A compressor takes humidity and contamination from the intake air, during the compression process these particles combine with the oil used in the compressor. All these impurities can cause wear and corrosion to the downstream equipment, with potential costly interruption to production, and reduction in the efficiency and service life of the equipment used. To reduce this negative impact, ABAC has developed a whole range of products to ensure air quality, increase efficiency and productivity and lengthen the life span of your equipment and tools.

WITHOUT Quality air Solutions	Customers benefits	WITH Quality Air Solutions
Goes to the net	Eliminate the water/dust produced during compressing process	Immediately
High risk	Your air network is clean and protected against rust	Ensure
High risk	A clean air network reduces leakage	Secured
Shorten	The life span of your operation process (machine/equipment...)	Prolong
Harm	Safe use of pneumatic tools, with extended life time	Protect
High	Cost of maintenance of your air network (corrosion), operation process and potential downtime	Low
Decrease	Quality of the final product, and potential risk of product recalls	Improve
Variable	Operating cost control	Stable
Reduce	Your productivity	Boost
Potential	Freezing (in the piping/air network)	Eliminate

Compressed air according to ISO 8573-1:2010

Purity class	Solid particles number of particles per m ³			Water Pressure dewpoint		Total oil* Concentration mg/m ³
	0,1 - 0,5 µm	0,5 - 1,0 µm	1,0 - 5,0 µm	°C	°F	
0	As specified by the equipment user or supplier and more stringent than Class 1.					
1	≤ 20,000	≤ 400	≤ 10	≤ -70	≤ -94	≤ 0,01
2	≤ 400,000	≤ 6,000	≤ 100	≤ -40	≤ -40	≤ 0,1
3	-	≤ 90,000	≤ 1000	≤ -20	≤ -4	≤ 1
4	-	-	≤ 10,000	≤ 3	≤ 37,4	≤ 5
5	-	-	≤ 100,000	≤ 7	≤ 44,6	-
6	≤ 5 mg/m ³			≤ 10	≤ 50	-

* Liquid, aerosol and vapour



Refrigeration Dryers

COOL range

It allows to achieve a pressure dew point of 5 ° C with a minimum footprint.

Components

- 1- Capillary hose
- 2- Refrigerant filter
- 3- Hot gas bypass valve
- 4- Timed solenoid drain
- 5- Control panel
- 6- Exchanger Air / refrigerating and air / air
- 7- Refrigerant compressor
- 8- Refrigerant condensor



Model	Part No	Max press bar	Air treatment capacity			Power W	Power supply V/Hz/ph	Connections gas input/output	Dimensionsi mm L x W x H	Weight Kg	Type of gas refrigerant
			l/min	CFM	m³/h						
COOL 21	4102003602	16	350	12.3	21	126	230/50/1	3/4" M	233 x 559 x 561	19	R 134 a
COOL 36	4102003603	16	600	21.2	36	126	230/50/1	3/4" M	233 x 559 x 561	19	R 134 a
COOL 51	4102003604	16	850	30	51	163	230/50/1	3/4" M	233 x 559 x 561	19	R 134 a
COOL 72	4102003605	16	1200	42.4	72	228	230/50/1	3/4" M	233 x 559 x 561	20	R 134 a
COOL 110	4102003606	16	1825	64.4	110	293	230/50/1	3/4" M	233 x 559 x 561	25	R 134 a
COOL 129	4102003607	13	2150	75.9	129	380	230/50/1	3/4" M	233 x 559 x 561	27	R 134 a
COOL 180	4102001849	13	3000	105.9	180	419	230/50/1	1" F	233 x 559 x 561	30	R 134 a
COOL 216	4102002070	13	3600	127.1	216	664	230/50/1	1" F	310 x 706 x 994	52	R 404 A
COOL 246	4102002071	13	4100	144.8	246	767	230/50/1	1' 1/2" F	310 x 706 x 994	57	R 404 A
COOL 312	4102002072	13	5200	183.6	312	865	230/50/1	1' 1/2" F	310 x 706 x 994	59	R 404 A
COOL 390	4102002073	13	6500	229.5	390	1028	230/50/1	1' 1/2" F	310 x 706 x 994	80	R 404 A
COOL 462	4102002074	13	7700	271.9	462	1242	230/50/1	1' 1/2" F	310 x 706 x 994	80	R 404 A

Ambient temperature				
°C	25	30	35	40
A	1,00	0,92	0,84	0,80

Reference conditions:

- Working pressure: 7 bar (100 psi)
- Operating temperature: 35 ° C
- Ambient temperature: 25 ° C
- Dew point under pressure: +5 ° C +/- 1
- Available in various voltages and frequencies

Limit conditions:

- Operating pressure: 16 bar COOL 21-216
13bar COOL 246-462
- Operating temperature: 50 ° C
- Ambient temperature min .: + 5 ° C; +40 ° C

Working temperature					
°C	30	35	40	45	50
A	1,24	1,00	0,82	0,69	0,58

Correction factor Formula for calculating the correction factor: $K = A \times B \times C$

Delivery correction factors for other conditions

Working Pressure												
bar	5	6	7	8	9	10	11	12	13	14	15	16
C	0,90	0,96	1,00	1,03	1,06	1,08	1,10	1,12	1,13	1,15	1,16	1,17



Refrigeration Dryers

DRY range

The refrigeration dryers to remove condensate and vapour so that dry compressed air is achieved and a continuous efficiency is preserve.

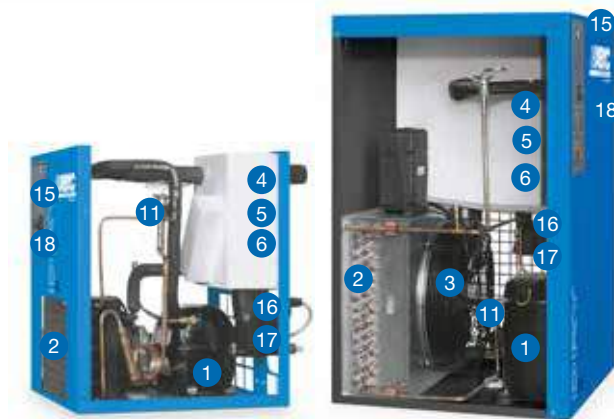

1. Refrigerant compressor driven by an electric motor, cooled using refrigerant fluid and protected against thermal overload.
2. Refrigerant condenser air-cooled and with a large exchange surface for high thermal exchange.
3. IP 54 motor-driven ventilator for the condenser cooling air flow.
4. Air/refrigerant evaporator with high thermal exchange and low leakage rates.
5. Condensate separator High-efficiency
6. Air – air heat exchanger with high thermal exchange and low load losses
7. Refrigerant fluid separator
8. Maximum pressure switch
9. Service valve
10. Pressure switch, fan control
11. Hot gas bypass valve controls the refrigerant capacity under all load conditions preventing any formation of ice within the system.
12. Refrigerant fluid filter
13. Capillary hose
14. Service valve
15. Instrument panel
16. Impurity filter for collecting any impurities to protect the system
17. Automatic discharge of condensate which is ecological and capable of preventing unwanted discharge of compressed air.

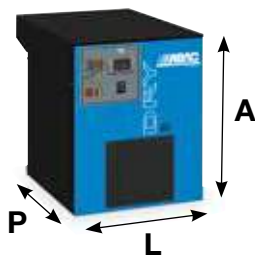

Model	Part No	Max press. bar	Flow rate			Power W	Power supply V/Hz/ph	Connections gas/DIN	Dimensions mm L x W x H	Weight kg
			l/min	CFM	m³/h					
DRY 20	4102000740	16	333	11.6	20	130	230/50/1	3/4" M	350 x 500 x 450	19
DRY 25	4102000741	16	417	16.6	25	130	230/50/1	3/4" M	350 x 500 x 450	19
DRY 45	4102000742	16	750	24.5	45	164	230/50/1	3/4" M	350 x 500 x 450	19
DRY 60	4102000743	16	1000	35.3	60	190	230/50/1	3/4" M	350 x 500 x 450	20
DRY 85	4102000744	16	1417	50	85	266	230/50/1	3/4" M	350 x 500 x 450	25
DRY 130	4102000745	16	2167	76.5	130	284	230/50/1	3/4" M	350 x 500 x 450	27
DRY 165	4102003223	13	2750	97.1	165	609	230/50/1	1" F	370 x 500 x 764	44
DRY 210	4102003224	13	3500	123.6	210	673	230/50/1	1" F	370 x 500 x 764	44
DRY 250	4102002718	13	4167	147.2	250	793	230/50/1	1 1/2" F	460 x 560 x 789	53
DRY 290	4102002719	13	4833	170.7	290	870	230/50/1	1 1/2" F	460 x 560 x 789	60
DRY 360	4102002720	13	6000	211.9	360	1072	230/50/1	1 1/2" F	460 x 560 x 789	65
DRY 460	4102002721	13	7667	270.8	460	1190	230/50/1	1 1/2" F	580 x 590 x 899	80
DRY 530	4102002722	13	8833	311.9	530	1446	230/50/1	1 1/2" F	580 x 590 x 899	80
DRY 690	4102003794	13	11500	406.1	690	1319	400/50/3	2" F	735 x 898 x 962	128
DRY 830	4102003795	13	13833	488.5	830	1631	400/50/3	2" F	735 x 898 x 962	146
DRY 1040	4102003796	13	17333	612.1	1040	1889	400/50/3	2" F	735 x 898 x 962	158
DRY 1260	4102003797	13	21000	741.6	1260	2110	400/50/3	2" F	735 x 898 x 962	165

Item number	Description	Price GBP
4101000653	Filters support bypass DRY20 - DRY130	332
4101000652	Filters support DRY20 - DRY130	98

Reference conditions:

- Working pressure: 7 bar (100 psi)
- Operating temperature: 35 ° C
- Ambient temperature: 25 ° C
- Dew point under pressure: +5 ° C +/- 1
- Available in various voltages and frequencies

Limit conditions:

- Operating pressure:
16 bar DRY 20-130 - 13 bar DRY 165-1260
- Operating temperature: 55 ° C
- Ambient temperature min .: + 5 ° C; +45 ° C

Correction factor Formula for calculating the correction factor: $K = A \times B \times C$

Delivery correction factors for other conditions

Ambient temperature					
°C	25	30	35	40	45
A	1,00	0,92	0,84	0,80	0,74 (DRY 20-DRY 530)
A	1,00	0,91	0,81	0,72	0,62 (DRY 690-DRY 1260)

Working temperature						
°C	30	35	40	45	50	55
B	1,24	1,00	0,82	0,69	0,58	0,45 (DRY 20-DRY 530)
B	1,00	1,00	0,82	0,69	0,58	0,49 (DRY 690-DRY 1260)

Working Pressure												
bar	5	6	7	8	9	10	11	12	13	14	15	16
C	0,90	0,96	1,00	1,03	1,06	1,08	1,10	1,12	1,13	1,15	1,16	1,17 (DRY 20-DRY 530)
C	0,90	0,97	1,00	1,03	1,05	1,07	1,09	1,11	1,12 (DRY 690-DRY 1260)			



Adsorption dryers

HAD range

To ensure clean compressed air with the deletion from the network of any residue of water and a higher productivity with reduced maintenance costs.

Applications



HAD 650-1300

1. Wide vessels for optimum air speed and reliable drying. Unit is rather low for its capacity due to flanges that are built into the vessels.
2. Air outlet connection.
3. Robust frame, including fork lift slots for easy installation.
4. Pressure Dew Point sensor (CD).
5. Pressure Dew Point digital display (CD).
6. Two manometers integrated in the control panel to show pressure in the two vessels.
7. Purge nozzle for regeneration.
8. Galvanized piping with flanged connections.
9. Inlet valves - long service interval.

HAD 90-940 (Image shows old model)

1. Base frame makes it easy to transport by fork lift.
2. Pressure gauge – tower A
3. Pressure gauge – tower B
4. Control dew point sensor (CD) as option.

HAD 7-60

1. Prefilter removes particulates and coalesced liquids from the air stream.
2. Removable front panel allows for easy access for servicing without disconnecting the pipe system.
3. Postfilters, integrated in the dryer, removes particulate in the air stream.
4. Electronic control housed in an IP65 box, which enables:
 - regeneration cycle management
 - regulation status
 - default diagnosis
 - remote default report
5. Multiport inlet and outlet



Model	Part No	Max Working Pressure		Operating Pressure	Air treatment capacity (at reference conditions)			Standard dew point	G 0,1 mg/m ³ oil 99,97% - 1 µm 99,87% - 0,01 µm	C 0,01 mg/m ³ oil 99,999% - 1µm 99,9992% - 0,01 µm	S 99,97% - 1 µm 99,87% - 0,01 µm	outlet connections	dimensions	Weight
		bar	bar		l/min	CFM	m ³ /h							
HAD 7 STD	8102822304	16	7,0	114	4.02	7	-40	n.d.	C 45	Integrated in the dryer	3/8"	281 x 92 x 445	13	
HAD 11 STD	8102822312	16	7,0	168	5.9	10	-40	n.d.	C 45			281 x 92 x 504	14	
HAD 18 STD	8102822320	16	7,0	282	10	17	-40	n.d.	C 45			281 x 92 x 635	17	
HAD 25 STD	8102822338	16	7,0	426	15	26	-40	n.d.	C 45			281 x 92 x 815	20	
HAD 40 STD	8102822346	16	7,0	708	25	42	-40	n.d.	C 45			281 x 92 x 1065	24	
HAD 60 STD	8102822353	16	7,0	990	35	59	-40	n.d.	C 90			281 x 92 x 1460	31	
HAD 90-40C 230V	8102364232	14	7,0	1500	53	90	-40	n.d.	C90	S 90	1/2"	401 x 620 x 1070	87	
HAD125-40C 230V	8102364240	14	7,0	2083	74	125	-40	n.d.	C 125	S 125	1/2"	401 x 620 x 1115	88	
HAD160-40C 230V	8102364257	14	7,0	2666	95	160	-40	n.d.	C 180	S 180	1"	401 x 620 x 1285	99	
HAD200-40C 230V	8102364265	14	7,0	3333	116	200	-40	n.d.	C 290	S 290		401 x 620 x 1465	114	
HAD235-40C 230V	8102364273	14	7,0	3916	137	235	-40	n.d.	C 290	S 290	1 1/2"	401 x 620 x 1615	124	
HAD325-40C 230V	8102364281	14	7,0	5416	190	325	-40	n.d.	C 505	S 505		571 x 620 x 1285	165	
HAD400-40C 230V	8102364299	14	7,0	6666	233	400	-40	n.d.	C 505	S 505		571 x 620 x 1465	197	
HAD470-40C 230V	8102364307	14	7,0	7833	275	470	-40	n.d.	C 505	S 505		571 x 620 x 1615	211	
HAD600-40C 230V	8102364315	14	7,0	10000	349	600	-40	n.d.	C 685	S 685		571 x 620 x 1915	245	
HAD700-40C 230V	8102364323	14	7,0	11666	413	700	-40	n.d.	C 935	S 935		738 x 620 x 1615	298	
HAD940-40C 230V	8102364331	14	7,0	15666	550	940	-40	n.d.	C 935	S 935	738 x 620 x 1915	328		
HAD 650 STD 11	8102823120	11	7,0	10800	381.3	648	-40	G 685	C 685	S 685	1 1/2"	1040 x 840 x 1760	445	
HAD 650 CD 11	8102823146	11	7,0	10800	381.3	648	-40	G 685	C 685	S 685		1040 x 840 x 1760	445	
HAD 800 STD 11	8102823153	11	7,0	13200	466.1	792	-40	G 935	C 935	S 935		1040 x 840 x 1760	445	
HAD 800 CD 11	8102823179	11	7,0	13200	466.1	792	-40	G 935	C 935	S 935		1040 x 840 x 1760	445	
HAD 1080 STD 11	8102823195	11	7,0	18000	635.6	1080	-40	G 1295	C 1295	S 1295	2"	1046 x 894 x 1876	600	
HAD 1080 CD 11	8102823211	11	7,0	18000	635.6	1080	-40	G 1295	C 1295	S 1295		1046 x 894 x 1876	600	
HAD 1300 STD 11	8102823237	11	7,0	21600	762.8	1296	-40	C 1295	C 1295	S 1295		1100 x 923 x 1914	650	
HAD 1300 CD 11	8102823252	11	7,0	21600	762.8	1296	-40	C 1295	C 1295	S 1295		1100 x 923 x 1914	650	

Standard features and options	HAD 7-60	HAD 90-940	HAD 650-1300
Capacity at 7 bar (-40 °C)	114-990 l/min	1500-15666 l/min	10800-21600 l/min
Dew point	Standard -40 °C	Standard -40 °C	Standard -40 °C
Working pressure range	4-16 bar	4-14 bar	4-11 bar & 11-14,5 bar
Voltages	12-24 V - DC 50/60 Hz, 100-115-230 V - AC 50/60 Hz	115-230 V - AC 50/60 Hz	230V - AC 50/60 Hz

Model	Part No	Description
HAD 7-60	8092260853	Wall/Foot Mounting Kit
HAD 650	0000020505	PDP -40 °C
HAD 800	0000020605	PDP -40 °C
HAD 1080	0000020705	PDP -40 °C
HAD 1003	0000020805	PDP -40 °C
HAD 650	0000020511	PDP -70 °C
HAD 800	0000020611	PDP -70 °C
HAD 1080	0000020711	PDP -70 °C
HAD 1300	0000020811	PDP -70 °C

Reference conditions:

- Working pressure: see the technical data table.
- Operating temperature: 35 °C
- Relative humidity: 100%

Limit conditions:

HAD 7-HAD 60

- Operating pressure: min./max. bar 4-16
- Operating temperature: min./max. °C 2-50
- Ambient temperature min min./max. °C 5-50

HAD 90-HAD 940

- Operating pressure: min./max. bar 4-14
- Operating temperature: min./max. °C 2-50
- Ambient temperature min min./max. °C 2-45

HAD 650-HAD 1300

- Operating pressure: min./max. bar 4-11 (HAD/11 project pressure) 11-14,5 (HAD/16 project pressure)
- Operating temperature: min./max. °C 2-50
- Ambient temperature min min./max. °C 2-40

*Model with discharge function

Filters are delivered unmounted along with the dryer:

HAD 7-60: The prefilter can be attached directly to the dryer.

HAD 90-1300: the filters have to be mounted on the air distribution line.

In case of different operating pressure from the reference conditions, use the table of correction factors

Correction factors		HAD/16 project pressure													
Inlet pressure - bar		4	5	6	7	8	9	10	11	12	13	14	14,5	15	16
HAD 7-HAD 60		0,62	0,75	0,87	1	1,12	1,25	1,37	1,5	1,62	1,75	1,87	1,93	2	2,12
HAD 90-HAD 940		0,62	0,75	0,87	1	1,12	1,25	1,37	1,5	1,62	1,75	1,87	1,93	-	-
Correction factors		HAD/11 project pressure							HAD/16 project pressure						
Inlet pressure - bar		4	5	6	7	8	9	10	11	11	12,5	13	14	14,5	-
HAD 650-HAD 1300		0,47	0,68	0,84	1	1,11	1,2	1,3	1,38	0,89	1	1,04	1,11	1,15	-
Correction factors		Inlet temperature °C													
		20	25	30	35	40	45	50	-	-	-	-	-	-	-
HAD 7-HAD 60		1,07	1,06	1,04	1	0,88	0,78	0,55	-	-	-	-	-	-	-
HAD 20-HAD 1300		1	1	1	1	0,84	0,71	0,55	-	-	-	-	-	-	-
Correction factors		Pressure dew point °C													
		-40	-70	-	-	-	-	-	-	-	-	-	-	-	-
HAD 7-HAD 1300		1	0,7	-	-	-	-	-	-	-	-	-	-	-	-

Filters

A complete range of filters to purify the air from forms of hydrocarbons, water and oil particulates.



Applications



Key benefits

- Air purification from contamination by
- Oil / powder
- Higher productivity and quality that allows you to prevent faults rather than repair them
- Greater efficiency and reliability
- Less wear of the distribution system and equipment
- Simple design and excellent performance
- Reduced maintenance costs
- Cartridges with different specifications filtering quality
- Quality higher final product



1. The head of the single kind design allows to reduce the pressure drop and increase savings.
2. A vent hole gives an audible alarm in the case where the filter is opened under pressure.
3. Remove the filter glass is very simple in that the outer ribs allow to have a perfect grip.
4. No problem of corrosion. The die-cast aluminum housing with special anodized treatment protects the filters both internally and externally.
5. Sight glass to easily monitor the level of condensate.
6. The regular filter drain guarantees excellent performance thanks to high-performance automatic float drains on (G - C - P) and manual drains on (V - S - D).



S FILTER RANGE

Particulate filters for dust protection.
Count Efficiency: 99,81% at Most Penetrating Particle Size (MPPS = 0,1 micron)
An S filter should be preceded by a dryer at all times.



G FILTER RANGE

Coalescing filters for general purpose protection, removing solid particles, liquid water and oil aerosol.
Total Mass Efficiency: 99%
For optimum filtration, a G filter should be preceded by a water separator.



D FILTER RANGE

High-efficiency particulate filters for dust protection.
Count Efficiency: 99,97% at Most Penetrating Particle Size (MPPS = 0,06 micron)
A D filter should be preceded by an S filter at all times and is commonly fitted after an adsorption dryer.



C FILTER RANGE

High-efficiency coalescing filters, removing solid particles, liquid water and oil aerosol.
Total Mass Efficiency: 99,9%
For optimum filtration, a C filter should be preceded by a G filter at all times.



P FILTER RANGE

Coalescing and particulate general purpose prefilter. Removing solid particles, dust, liquid water and oil aerosol.
Total Mass Efficiency: 90%



V FILTER RANGE

Activated carbon filter for removal of oil vapour and hydrocarbon odors with a maximum remaining oil content of 0,003 mg/m³ (0,003 ppm).
1000 hour lifetime

	S	D	P	G	C	V
Type filter	Particelle solide	Solid particles	Aerosol oil and solid particles	Aerosol oil and solid particles	Aerosol oil and solid particles	Steam Oil
Reference standard for testing	ISO 12500-3	ISO 12500-3	ISO 12500-1 / ISO 12500-3 / ISO 8573-2	ISO 12500-1 / ISO 8573-2	ISO 12500-1 / ISO 8573-2	ISO 8573-5
Incoming oil concentration (mg / m ³)	NA	NA	10	10	10	0,01
particulate filtration efficiency (% In MPPS)	(MPPS=0,1 µm) 99,81	(MPPS=0,06 µm) 99,97	(MPPS=0,1 µm) 89,45	NA	NA	NA
filtration efficiency ((% a 1 µm)	99,97	99,999	94,19	NA	NA	NA
filtration efficiency ((% a 0,01 µm)	99,87	99,992	93,63	NA	NA	NA
Entrainment of maximum oil (mg/m ³)	NA	NA	1	0,1	0,01	0,003
Dry pressure drop (mbar)	120	140	85	NA	NA	160
Pressure drop in service (mbar)*	NA	NA	115	205	240	NA
pressure drop in operation (mbar), in a typical installation of compressors	NA	NA	NA	185	200	NA
element maintenance	After 4.000 hours of operation or 1 year or with a pressure drop of > 350 mbar	After 4,000 operating hours or 1 year or a drop in pressure > 350 mbar	After 4,000 hours of operation or 1 year	After 4,000 hours of operation or after one year	After 4,000 hours of operation or after one year	After 1000 hours of operation (20 ° C) or 1 year
preceded by	-	S	-	water separator	G	G & C

Filter type	Capacity* nominal			Maximum pressure bar	Connections / port thread G	Dimensions			Free space for cartridge replacement D mm	Weight kg
	l/min	CFM	m ³ /h			A mm	B mm	C mm		
FILTER 45	720	25.4	43	16	3/8"	90	21	228	75	1
FILTER 90	1500	53	90	16	1/2"	90	21	228	75	1,1
FILTER 125	2100	74.2	126	16	1/2"	90	21	283	75	1,3
FILTER 180	3000	105.9	180	16	3/4"	110	27,5	303	75	1,9
FILTER 180	3000	105.9	180	16	1"	110	27,5	303	75	1,9
FILTER 290	4800	169.5	288	16	1"	110	27,5	343	75	2,1
FILTER 505	8400	296.6	504	16	1 1/2"	140	34	449	100	4,2
FILTER 685	11400	402.6	684	16	1 1/2"	140	34	532	100	4,5
FILTER 935	15600	550.9	936	16	1 1/2"	140	34	532	100	4,6
FILTER 1295	21600	762.8	1296	16	2"	179	50	618	150	6,9
FILTER 1295	21600	762.8	1296	16	2 1/2"	179	50	618	150	6,9
FILTER 1890	31500	1112.4	1890	16	3"	210	57	720	200	11,0
FILTER 2430	40500	1430.2	2430	16	3"	210	57	890	200	12,6



* Reference condition: pressure 7 bar (102 psi). Maximum operating temperature of 66°C, and 35°C, only for V range.
Minimum operating temperature of 1°C.

Correction factor for different operating pressures												
Compressed air pressure other than the exercise, you need to multiply the filter capacity for the following correction factors:												
Inlet pressure (bar)	1	2	3	4	5	6	7	8	10	12	14	16
Correction factor	0,38	0,53	0,65	0,75	0,83	0,92	1	1,06	1,2	1,31	1,41	1,5

Complete filter

Filter type	S	D	P	G	C	V	
	Part No	Part No	Part No	Part No	Part No	Part No	
FILTER 45	8102850586	8102850842	8102849828	8102849950	8102850719	8102850974	
FILTER 90	8102850594	8102850859	8102849836	8102849968	8102850727	8102850982	
FILTER 125	8102850602	8102850867	8102849844	8102849976	8102850735	8102850990	
FILTER 180 (1")	8102850628	8102850883	8102849869	8102849992	8102850750	8102851014	
FILTER 180 (3/4")	8102850610	8102850875	8102849851	8102849984	8102850743	8102851006	
FILTER 290	8102850636	8102850891	8102849877	8102850503	8102850768	8102851022	
FILTER 505	8102850644	8102850909	8102849885	8102850511	8102850776	8102851030	
FILTER 685	8102850651	8102850917	8102849893	8102850529	8102850784	8102851048	
FILTER 935	8102850669	8102850925	8102849901	8102850537	8102850792	8102851055	
FILTER 1295 (2 1/2")	8102850685	8102850941	8102849927	8102850552	8102850818	8102851071	
FILTER 1295 (2")	8102850677	8102850933	8102849919	8102850545	8102850800	8102851063	
FILTER 1890	8102850693	8102850958	8102849935	8102850560	8102850826	8102851089	
FILTER 2430	8102850701	8102850966	8102849943	8102850578	8102850834	8102851097	

Typical filters installations

1. Compressor with aftercooler
2. Filter G grade
3. Filter C grade
4. Filter V grade
5. Filter S grade
6. Filter D grade
7. Filter P grade
8. Refrigerant air dryer
9. Adsorption dryer

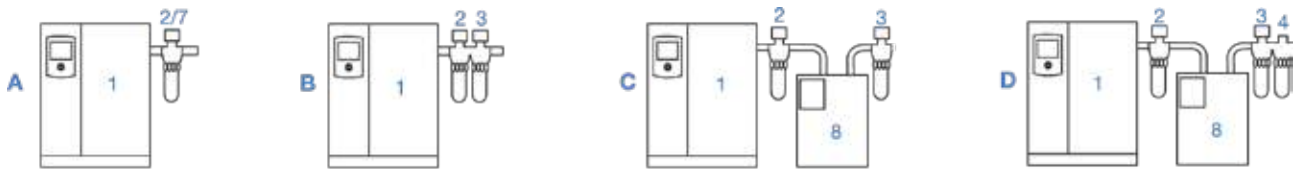

A. general purpose Protection

(Air purity in accordance with ISO 8573-1: G Filter Class 2: -: 3 and Filter P Class 4: -: 3)

B. general purpose protection and reduced oil concentration

(Air purity in accordance with ISO 8573-1: class 1: -: 2)

C. High Quality Air with reduced dew point

(Air purity in accordance with ISO 8573-1: class 1: 4: 2)

D. high quality air with dew point and concentration of reduced oil

(Air purity in accordance with ISO 8573-1: class 1: 4: 1)

E. Air of high quality with extremely low dew point

(Purity according to ISO 8573-1: Class 2: 2: 1)

F. Air of high quality with extremely low dew point

(Air purity in accordance with ISO 8573-1: class 1: 2: 1)

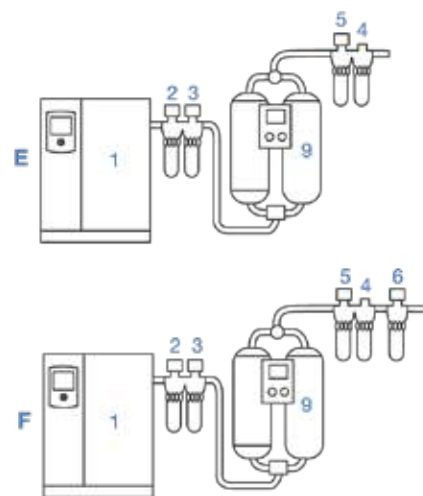

Spare parts cartridge for filters

Filter type	P	G/S	C/D	V	
	Part No	Part No	Part No	Part No	
FILTER 45	2258290101	2258290112	2258290123	2258290134	
FILTER 90	2258290102	2258290113	2258290124	2258290135	
FILTER 125	2258290103	2258290114	2258290125	2258290136	
FILTER 180	2258290104	2258290115	2258290126	2258290137	
FILTER 290	2258290105	2258290116	2258290127	2258290138	
FILTER 505	2258290106	2258290117	2258290128	2258290139	
FILTER 685	2258290107	2258290118	2258290129	2258290140	
FILTER 935	2258290108	2258290119	2258290130	2258290141	
FILTER 1295	2258290109	2258290120	2258290131	2258290142	
FILTER 1890	2258290110	2258290121	2258290132	2258290143	
FILTER 2430	2258290111	2258290122	2258290133	2258290144	

Options



- Pressure gauge
- Voltage free contact mounted on the differential pressure gauge to give remote indication of the cartridge replacement



- Pressure indicator
- Serial Connection Kit allows easy mounting of filters in range
- Wall mounting kit to simplify installation



- Quick coupling for easy connection to fix an intelligent drain with no loss of compressed air

Part No	Option	Available for	
8092242968	Kit for wall installation	From FILTER 45 to 125	
8092242976	Kit for wall installation	FILTER 180 - 290	
8092242984	Kit for wall installation	From FILTER 505 to 935	
8092242992	Kit for wall installation	FILTER 1295	
8092243008	Kit for wall installation	FILTER 1890 - 2430	
8092243016	Serial connection kit	From FILTER 45 to 125	
8092243024	Serial connection kit	FILTER 180 - 290	
8092243032	Serial connection kit	From FILTER 505 to 935	
8092243040	Serial connection kit	FILTER 1295	
8092243057	Serial connection kit	FILTER 1890 - 2430	
8055216447	NA contact potential free	(Only in combination with the pressure gauge)	
8055216488	NC contact potential free	(Only in combination with the pressure gauge)	
1624117200	Differential pressure gauge	From FILTER 45 to 2430	
1617704800	Differential pressure indicator	From FILTER 45 to 2430	
2901056200	Kit viewer level condensates	From FILTER 45 to 2430	
2901056300	Automatic drain valve	From FILTER 45 to 2430	
2901061100	Manual drain valve	From FILTER 45 to 2430	
1617708202	QUICK COUPLING G 1/4 FEMALE	From FILTER 45 to 2430	
1617708201	QUICK COUPLING G 1/8+ MALE	From FILTER 45 to 2430	
2901206804	KIT Drain PNL 50-230 V 50/60 Hz	All	
2901206805	KIT Drain PNL 50-110 V 50/60 Hz	All	
2901206806	KIT Drain PNL 50-24 V 50/60 Hz	All	



Condensate drains

A complete range of automatic drains, widely used throughout the compressed air industry to discharge condensate from air receivers, filters, dryers, and condensate separators.



G120 - Mechanical condensate drain

The mechanical condensate drain G120 requires no electrical connection and is recommended for use in areas with danger of fire or explosion



E200 - Timed condensate drain

The timed condensate drain works with a servo-valve which periodically it opens based on the time set on the timer



LD - Intelligent condensate drain

The LD range functions using a system called capacitive condensate discharge. Compared to the traditional timer condensate discharge system, it has several advantages.

Model	Part No	range of operating pressure bar	Compressor capacity m ³ /h	Dryer capacity m ³ /h	Filter capacity m ³ /h	Connection Ø	power supply Volt/Herz	Class of protection IP	
Mechanical G120	0079500000	0-16	5,000	10,000	50,000	1/2"	-	-	
Timer E200	0079520000	0-16	5,000	10,000	50,000	3/8"	230/50	IP65	
Electronic LD200	4101000212	0.2-16	900	1,800	9,000	1/2"	230/50	IP65	
Electronic LD202	4101000213	0.2-16	1,800	3,600	18,000	1/2"	230/50	IP65	
Electronic LD203	4101000214	0.2-16	9,500	19,000	95,000	1/2"	230/50	IP65	



Oil-water separators

The WS Series oil-water separators collect the separated residual oil in a suitable container allowing the water which has been cleared of impurities to be drained. They represent a valid and economical solution to separate oil from condensate and offer a solution in-line with ecological legislation.

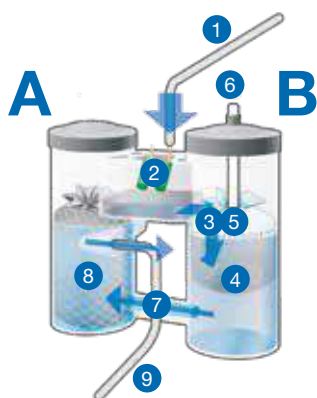

1. Collection of any type of condensate including a mix of different oils
2. Condensates are collected through mufflers located in an expansion chamber where first stage separation takes place by depressurization.
3. Water/oil emulsion enters column A and passes through an oleophilic media, made of oil absorbing fibres which allow water to pass through.
4. The oleophilic filter floats in column A. This is advantageous for absorbing residual oil floating on the surface.
5. The weight of the filter increases as oil saturation increases. Oil progressively begins to reach the service indicator. Part of the filter that is not saturated keeps in contact with the water surface.
6. When the filter is totally saturated, there is indication that the filter needs to be changed.
7. Only cleaned condensate from the bottom of column A flows to column B.
8. Column B contains activated carbon, and absorbs the remaining oil in the condensate. The large capacity of the system prevents any risk of spillage in case of blockage of the system or if the system produces excessive quantities of condensate.
9. Oil content is approximately 15mg/l, at reference conditions, at the outlet, a level that allows disposal of the condensate into the foul drain without risk to the environment.



Model	Part No	Installation Flow with dryer		Installation Flow without dryer		Connections		a mm	b mm	c mm	Weight kg
		L/min	CFM	L/min	CFM	inlet 1	inlet 2				
WS13	8102045989	2100	74.1	2700	95.3	1 x 1/2"	1 x 1/2"	470	165	600	4
WS34	8102045997	5700	201.3	7083	250.1	2 x 1/2"	1 x 1/2"	680	255	750	13
WS52	8102046003	8700	307.2	10500	370.8	2 x 1/2"	1 x 1/2"	680	255	750	15
WS128	8102046011	21300	752.2	26100	921.7	2 x 3/4"	1 x 3/4"	750	546	900	25
WS218	8102046029	36300	1281.9	45600	1610.3	2 x 3/4"	1 x 3/4"	750	546	1030	26
WS297	8102046037	49500	1748	61200	2161.2	2 x 3/4"	1 x 3/4"	945	650	1100	28
WS425	8102046045	70800	2500	87300	3082.9	2 x 3/4"	1 x 3/4"	945	695	1100	30
WS850	8102046052	141600	5000.5	174600	5212.4	2 x 3/4"	1 x 1"	945	1185	1100	60

Note

Reference conditions

residual oil equal to 15 mg/l.

Mild temperature environment (25 ° C with 60% relative humidity)

Correction factors: multiply the flow indicated by the appropriate correction factor.

Cold ambient (15 °C/60% UR)	with Dryer	without Dryer							
Correction factor	1,80	2,30							
Hot ambient (35 °C/70% UR)	with Dryer	without Dryer							
Correction factor	0,45	0,40							
Duty Cycle: hours a day	8	10	12	14	16	18	20	22	24
Correction factor	1,50	1,20	1,00	0,86	0,75	0,67	0,60	0,55	0,50
10 mg/l of residual oil correction factor of 0,67									

Maintenance Kit

In order to ensure consistent performance and a prompt maintenance are available of the maintenance kit. Each kit has been carefully designed to simplify all maintenance operations and ensure proper operation. The cartridge can be replaced quickly by removing the separator lid. Together with the filter kit is provided a container for the removal of old filters without spillage.



For each type of oil-water separator are three maintenance kit:

- The Maintenance Kit A contains everything needed to run a replacement of the oil separator. This kit is indicated for the first service after installation under normal moisture conditions. Then you can use the service kit aD
- The maintenance kit B contains everything needed to run two replacements of oil removal and replacement of the activated carbon filter. This kit is indicated under normal moisture conditions. The duration of the active carbon filter is twice higher than that of the oil separator.
- The maintenance kit D contains everything needed to run a replacement of the oil separator is that the active carbon filter. We recommend the use of this kit when the condensate contains a considerable amount of oil, such as to saturate all filters simultaneously.
- Note: The maintenance kit includes a speaker, silencers and filter holder containers.



Cyclonic separators

The cyclonic separators use centrifugal force to remove condensation droplets which have condensed in the flow of compressed air due to reduction in temperature.



Model	Part No	Flow rate		Output connection	Dimensions mm			
		L/min	CFM		A	B	C	D
ASA1	8973020269	2,000	0.072	3/8"	187	88	21	60
ASA2	8973020270	2,583	0.091	1/2"	187	88	21	60
ASA3	8973020271	3,917	0.138	3/4"	256	88	21	80
ASA4	8973020272	6,083	0.214	1"	262	125	33	100
ASA5	8973020273	12,833	0.453	1-1/2"	452	125	33	140
ASA6	8973020274	21,333	0.753	2"	695	163	48	520
ASA7	8973020275	41,000	1.447	2"-1/2"	695	163	48	520

with manual drain



Vertical air receivers

Supplied with all necessary fittings. When using an intermittent air supply they act as a buffer and a storage medium which allows the distribution system to temporarily sustain an air consumption which can be slightly higher than the capacity of the compressor.

Capacity	100		200		270		500				720		900		1000						
Type	Paint	Galv.	Paint	Galv.	Paint	Galv.	Paint	Galv.	Paint	Galv.	Paint	Galv.	Paint	Galv.	Paint	Galv.	Paint	Galv.			
Pressure (bar)	11		11		11		11				16		10,8		11		12	11,5	16		
Diameter Ø	370		446	430	500		600				600	750	790	800	790	800	790	800	790	800	790
H tot (mm)	1172	1229	1570	1601	1668	1685	2055	2077	2055	2120	2030	1863	2120	2213	2315	2345	2315	2345	2315	2345	
H (mm)	124	176	174	196	170	192	155	174	155	175	150	200	130	200	115	200	115	200	115	200	
a	3/4"		1"	3/4"	1"	3/4"	1"	1"1/2"	1"	2"	1"	1"1/2"	1"1/2"	2"	2"	2"	2"	2"	2"	2"	
b	3/4"		1"	3/4"	1"	3/4"	1"	1"1/2"	1"	2"	1"	1"1/2"	1"1/2"	2"	2"	2"	2"	2"	2"	2"	
c	3/8"		3/8"	3/4"	3/8"	3/4"	3/8"	3/4"	3/8"	3/4"	3/8"	3/4"	3/8"	3/4"	3/8"	3/4"	3/8"	3/4"	3/8"	3/4"	
d	3/8"		3/8"		n.a.	3/8"	n.a.	3/8"	n.a.	3/8"	3/8"	3/8"	3/8"	3/8"	3/8"	3/8"	3/8"	3/8"	3/8"	3/8"	
e	1/2"	2"	1/2"	1"1/4"	1/2"	2"	2"	1"1/4"	2"	2"	2"	1"1/4"	2"	1"1/4"	2"	1"1/4"	2"	1"1/4"	2"	2"	
f	1/2"	2"	1/2"	1"1/4"	1/2"	2"	2"	1"1/4"	2"	2"	2"	1"1/4"	2"	1"1/4"	2"	1"1/4"	2"	1"1/4"	2"	2"	
l (mm)	298	447	397		599	442	775	689	775	485	895	690	860	800	745	725	745	725	745	725	
m (mm)	998	1055	1222	1357	1304	1422	1560	1689	1560	1745	1705	1440	1780	1800	1685	1725	1685	1725	1685	1725	
Type of kit included	1		2/A		3	A	4	A	5	C	4	A	6	A	7	B	8	C			
Weight (kg)	37	40	51	55/50	62	66/60	127	143/130	159	176/160	180	184/167	200	209/190	204	224/204	246	308/280			
Norms and standards	87/404/CE											97/23/CE (PED)									

Capacity	1500		2000		3000		4000		5000	
Type	Paint	Galv.	Paint	Galv.	Paint	Galv.	Paint	Galv.	Paint	Galv.
Pressure (bar)	11,5		11,5		16		11,5		16	
Diameter Ø	1000		1000		1200		1450		1430	
H tot (mm)	2305		2805		2810		2965		2930	
H (mm)	180		180		175		185		170	
a	2"		2"		3"		2"		3"	
b	2"		2"		3"		2"		3"	
c	3/4"		3/4"		3/4"		3/4"		3/4"	
d	3/8"		3/8"		3/8"		3/8"		3/8"	
e	1"1/4"		1"1/4"		2"		1"1/4"		2"	
f	1"1/4"		1"1/4"		2"		1"1/4"		2"	
l (mm)	590		595		565		700		645	
m (mm)	1860		2355		2340		2410		2370	
Type of kit included	B		B		C		B		C	
Weight (kg)	278/306/278		352/387/352		490/539/490		537/591/537		620/682/620	
Norms and standards	802/882/802		905/995/905		923/1025/932		1055/1160/1055		97/23/CE (PED)	

Model	Part No	Litres	Bar	Kit	
Painted vertical air receivers blue					
V100 11B	2236100970	100	11	KIT 1	
V200 11B	2236100971	200	11	KIT 2	
V270 11B	2236100972	270	11	KIT 3	
V500 11B	2236100973	500	11	KIT 4	
V720 11B	2236100974	720	10,8	KIT 4	
V900 11B	2236100975	900	11	KIT 6	
V1000 12B	2236100976	1000	12	KIT 7	
V1500 12B	4101000924	1500	12	KIT B	
V2000 12B	4101000928	2000	11,5	KIT B	
V3000 12B	4101000932	3000	11,5	KIT B	
V4000 12B	4101000936	4000	11,5	Not included	
V5000 12B	4101000940	5000	11,5	Not included	
Galvanized vertical air receivers					
V200 11B ZINC	4101000902	200	11	KIT A	
V270 11B ZINC	4101000906	270	11	KIT A	
V500 11B ZINC	4101000910	500	11	KIT A	
V725 10,8B ZINC	4101000914	725	10,8	KIT A	
V900 11B ZINC	4101000918	900	11	KIT A	
V1000 11,5B ZINC	4101000922	1000	11,5	KIT B	
V1500 11,5B ZINC	4101000926	1500	11,5	KIT B	
V2000 11,5B ZINC	4101000930	2000	11,5	KIT B	
V3000 11,5B ZINC	4101000934	3000	11,5	KIT B	
V4000 11,5B ZINC	4101000938	4000	11,5	Not included	
V5000 11,5B ZINC	4101000942	5000	11,5	Not included	
Painted vertical air receivers blue high pressure					
V500 15B	2236100977	500	15	KIT 5	
V1000 15B	2236100978	1000	15	KIT 8	
V2000 16B	4101000950	2000	16	KIT C	
V3000 16B	4101000969	3000	16	KIT C	
V4000 16B	4101000972	4000	16	Not included	
V5000 16B	4101000975	5000	16	Not included	
Galvanized vertical air receivers high pressure					
V500 16B ZINC	4101000963	500	16	KIT C	
V1000 16B ZINC	4101000965	1000	16	KIT C	
V2000 16B ZINC	4101000967	2000	16	KIT C	
V3000 16B ZINC	4101000970	3000	16	KIT C	
V4000 16B ZINC	4101000973	4000	16	Not included	
V5000 16B ZINC	4101000976	5000	16	Not included	

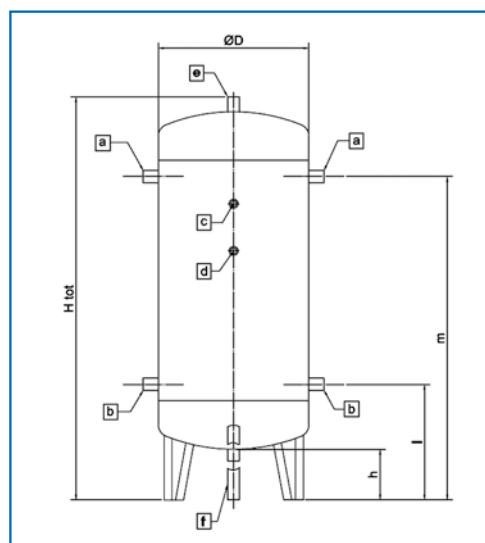

Composition of the accessory kit

	KIT A	KIT B	KIT C
Gauge valve	1	1	1
Ball valve 3/8 "	-	-	-
Ball valve 3/4 "	-	-	1
Manual drain valve 1 1/4 "	1	1	-
Safety valve	1	1	1
Gauge 50mm / 100mm	1	1	1

	KIT 1	KIT 2	KIT 3	KIT 4	KIT 5	KIT 6	KIT 7	KIT 8
Cap 3/8 AND GAS C	1	1	-	1	-	1	-	-
Ball valve 1/2 "MF	2	2	1	-	-	-	1	1
Ball valve 3/4 "MF	-	-	1	1	1	1	-	-
Ball cock 1 "MF	-	-	1	1	1	1	-	-
Reduction 1/2 "M 3/8" F	1	1	1	-	-	-	-	-
Reduction 3/4 "1/2"	1	-	-	-	-	-	1	1
Reduction 1 1/2 "F	-	1	-	-	-	1	-	-
Reduction 1 3/4 "F	-	-	1	2	1	-	-	-
Reduction 3/4 "3/8"	-	-	-	1	1	-	-	-
Reduction 3/8 "1/4"	1	1	1	1	1	1	1	1
Elbow fitting	1	1	1	1	1	1	2	1
Safety valve	1	1	1	1	1	1	1	1
Gauge 50mm / 100mm	1	1	1	1	1	1	1	1
fitting galvanized	-	-	1	4	4	4	4	4
x test flange testing	-	-	-	-	-	-	1	1