

REV. NO.		REVISIONS	DATE	APPROVED
ZONE	REV.	DESCRIPTION		

**Precision Sheet Metal**  
 Design ♦ Engineering ♦ Fabrication  
 www.acumetalfab.com

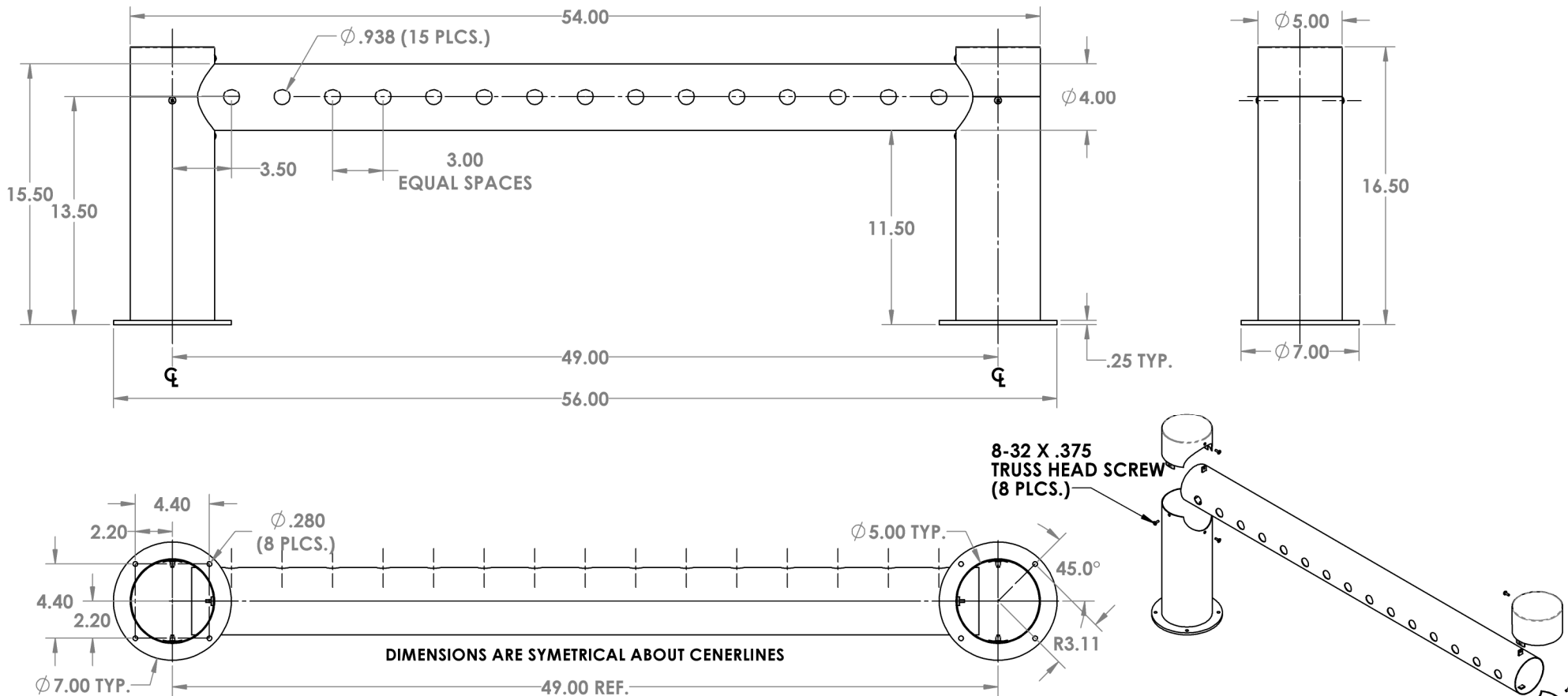

**NOTES:**

**ALL DIMENSIONS ARE OUTSIDE DIMENSIONS (UNLESS OTHERWISE NOTED)**

**MATERIAL:**

- Ø 4.00 X .06 WALL 304 STAINLESS STEEL TUBE
- Ø 5.00 X .06 WALL 304 STAINLESS STEEL TUBE

2 EA.	BASE TUBE	81026-01
2 EA.	TOP TUBE	81026-02
1 EA.	CROSS TUBE	81026-23

**PART # 81026-PT54**

PROPRIETARY AND CONFIDENTIAL  
 THE INFORMATION CONTAINED IN THIS DRAWING IS THE SOLE PROPERTY OF ACU PRECISION SHEET METAL. ANY REPRODUCTION IN PART OR AS A WHOLE WITHOUT THE WRITTEN PERMISSION OF ACU PRECISION SHEET METAL IS PROHIBITED.  
 ACU PRECISION SHEET METAL IS : AMERICAN COFFEE URN MANUFACTURING CO., INC

	NAME	DATE
DRAWN	L. WILLIAMS	03/18
MATERIAL	SEE NOTES	
FINISH	#8 POLISHED	

TITLE:
<b>4 X 5 METRO PASS THROUGH TOWER 15 HOLE, 54" PASS THROUGH</b>
<b>AMERICAN COFFEE URN</b>