

CHANGE DIMENSIONS AS NEEDED FOR CUSTOM TOWERS

REV. NO.		REVISIONS	DATE	APPROVED

Precision Sheet Metal
 Design ♦ Engineering ♦ Fabrication
 www.acumetalfab.com

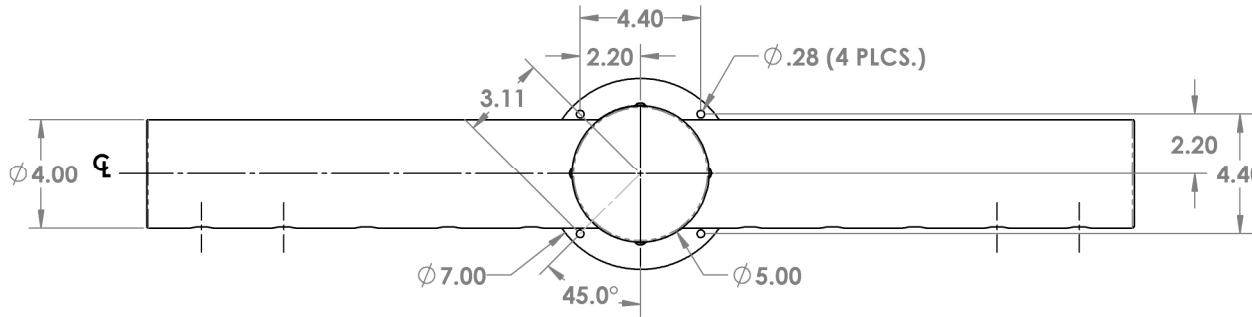

**8-32 X .375"
 TRUSS HEAD SCREW
 (8 PLCS.)**

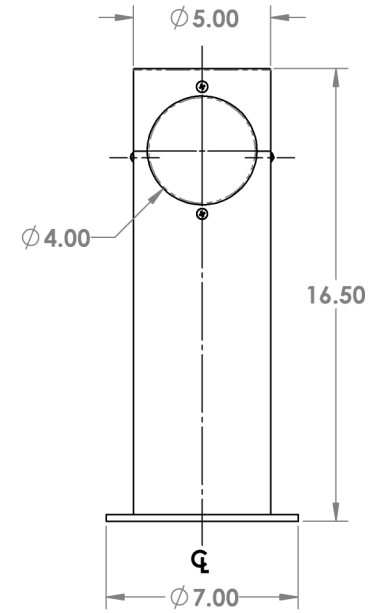
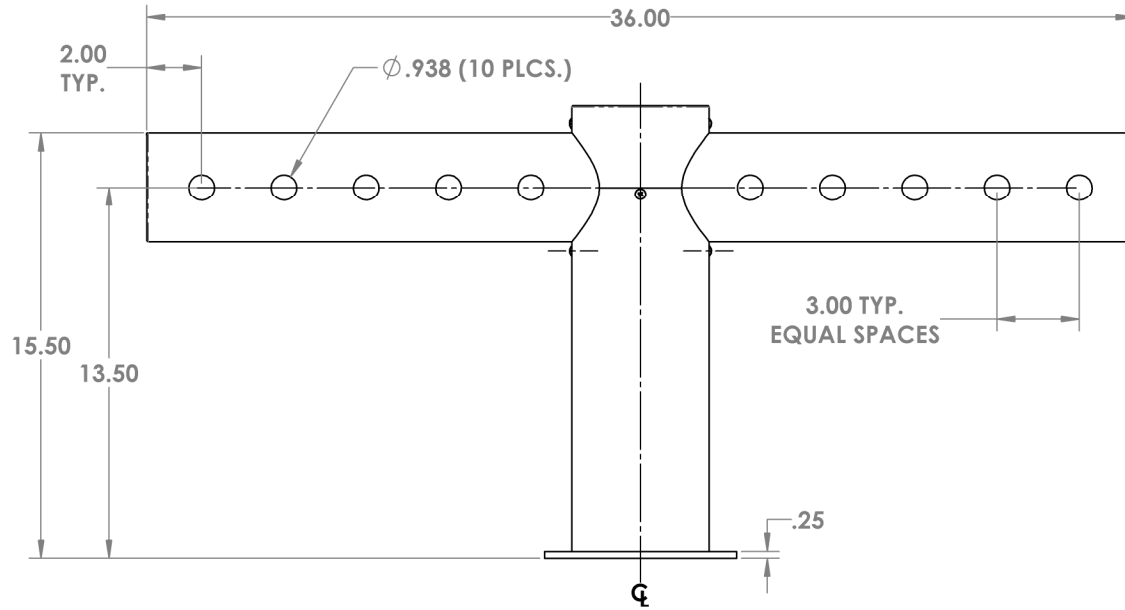
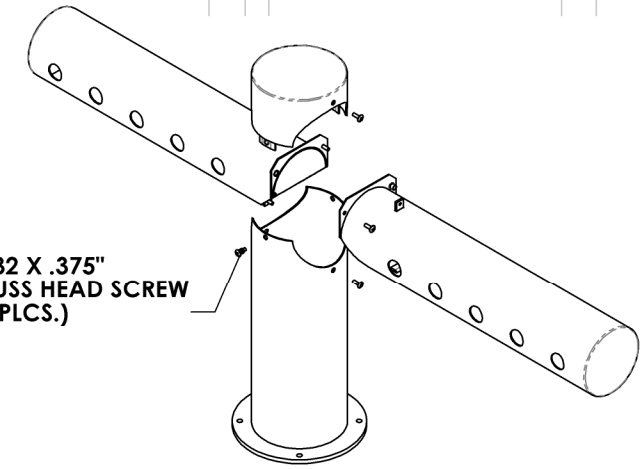

NOTES:

**ALL DIMENSIONS ARE OUTSIDE DIMENSIONS
 (UNLESS OTHERWISE NOTED)**

MATERIAL:

- Ø 4.00 X .06 WALL 304 STAINLESS STEEL TUBE
- Ø 5.00 X .06 WALL 304 STAINLESS STEEL TUBE

PROPRIETARY AND CONFIDENTIAL
 THE INFORMATION CONTAINED IN THIS DRAWING IS THE SOLE PROPERTY OF ACU PRECISION SHEET METAL. ANY REPRODUCTION IN PART OR AS A WHOLE WITHOUT THE WRITTEN PERMISSION OF ACU PRECISION SHEET METAL IS PROHIBITED.
 ACU PRECISION SHEET METAL IS:
 AMERICAN COFFEE URN MANUFACTURING CO., INC

BASE TUBE	81026-08
TOP TUBE	81026-20
RIGHT TEE TUBE	81026-26
LEFT TEE TUBE	81026-27
NAME	DATE
DRAWN L. WILLIAMS	03/18
MATERIAL	SEE NOTES
FINISH	#8 POLISHED

PART # 81026-T36

TITLE:	
4 X 5 METRO TEE TOWER 10 HOLE, 36" TEE TOWER	
AMERICAN COFFEE URN	