



TRUE MANUFACTURING CO., INC.
U.S.A. FOODSERVICE DIVISION

2001 East Terra Lane • O'Fallon, Missouri 63366-4434 • (636)240-2400
Fax (636)272-2408 • Toll Free (800)325-6152 • Intl Fax# (001)636-272-7546
Parts Dept. (800)424-TRUE • Parts Dept. Fax# (636)272-9471 • www.truemfg.com

Project Name: _____

Location: _____

Item #: _____ Qty: _____

Model #: _____

A/A #

SIS #

Model:
TAC-48~TSL01

Vertical Air Curtains:
Refrigerator~True Standard Look Version 01



TAC-48~TSL01

- ▶ True's air curtain merchandisers are designed with enduring quality that protects your long term investment.
- ▶ Designed using the highest quality materials and components to provide the user with colder product temperatures and lower utility costs in an attractive merchandiser that brilliantly displays food and beverages.
- ▶ Large, open front allows easy access to display levels and places maximum attention on merchandising.
- ▶ Oversized, factory balanced, refrigeration system holds 35°F to 40°F (1.6°C to 4.4°C).
- ▶ Patented reversing condenser fan motors. Fan motors reverse during defrost off cycles to help keep condenser coil free from dirt, dust and debris. Keeping coils clean optimizes the unit's performance providing colder holding temperatures and increased energy efficiency. Regularly scheduled thorough cleaning of coils still recommended.
- ▶ Exterior - non-peel or chip black powder coated cold rolled steel; durable and permanent.
- ▶ Interior - attractive, NSF approved, white aluminum liner. Stainless steel interior floor and deck pans.
- ▶ Durable and permanent non-peel or chip white vinyl exterior with white aluminum interior and stainless steel floor and deck pans.
- ▶ Four (4) adjustable, solid white powder coated cantilever shelves, adjustable for up to 15° tilt in 5° increments. Each shelf is equipped with an LED light strip to provide 5 levels of even lighting throughout the cabinet.
- ▶ Entire cabinet structure is foamed-in-place using a high density, polyurethane insulation that has zero ozone depletion potential (ODP) and zero global warming potential (GWP).

ROUGH-IN DATA

Specifications subject to change without notice.
Chart dimensions rounded up to the nearest 1/8" (millimeters rounded up to next whole number).

Model	Shelves	Cabinet Dimensions (inches) (mm)			HP	Voltage	Amps	NEMA Config.	Cord Length (total ft.) (total m)	Crated Weight (lbs.) (kg)
		W	D	H						
TAC-48~TSL01	4	48 1220	29 1/4 743	80 3/8 2048	1 1/2	208/230/60	12.0	6-15P	9 2.74	TBD TBD

Requires 208-230/60 Hz, single phase, NEMA 6-15R.



APPROVALS:

AVAILABLE AT:

Model:
TAC-48~TSL01

Vertical Air Curtains: Refrigerator~True Standard Look Version 01



STANDARD FEATURES

DESIGN

- Designed using the highest quality materials and components to provide the user with colder product temperatures and lower utility costs in an attractive merchandiser that brilliantly displays packaged food and beverages.

REFRIGERATION SYSTEM

- Factory engineered, self-contained, capillary tube system using environmentally friendly (CFC free) R404A refrigerant.
- Time-initiated, time-terminated off cycle defrost system.
- Extra large evaporator coil and condenser balanced with higher horsepower compressor; maintains cabinet temperatures of 35°F to 40°F (1.6°C to 4.4°C) for the best in food preservation.
- Sealed, cast iron, self-lubricating evaporator fan motors.
- Bottom mounted condensing unit positioned for easy maintenance.
- Patented reversing condenser fan motor(s). Fan motor(s) reverse during defrost off cycles to help keep condenser coil free from dirt, dust and debris. Keeping coils clean optimizes the unit's performance providing colder holding temperatures and increased energy efficiency. Regularly scheduled thorough cleaning of coils still recommended.

CABINET CONSTRUCTION

- Exterior - non-peel or chip black powder coated cold rolled steel; durable and permanent.
- Plexiglass lower front panel; durable and break resistant.
- Interior - attractive, NSF approved, white aluminum liner. Stainless steel interior floor and deck pans.
- Insulation - entire cabinet structure is foamed-in-place using a high density, polyurethane insulation that has zero ozone depletion potential (ODP) and zero global warming potential (GWP).
- Welded, heavy duty steel frame rail, black powder coated for corrosion protection.
- Frame rail fitted with leg levelers.

- Illuminated exterior sign panel. Variety of sign options available.

SHELVING

- Four (4) adjustable, solid white powder coated cantilever shelves, adjustable for up to 15° tilt in 5° increments.
- shelves are 44"W x 15 1/32"D (1118 mm x 395 mm).
- Each shelf is equipped with an LED light strip to provide 5 levels of even lighting throughout the cabinet.

LIGHTING

- 5 Levels of LED interior lighting provides more even lighting throughout the cabinet. Safety shielded.

MODEL FEATURES

- Perforated interior back wall for more efficient airflow.
- Complies with NSF/ANSI Standard 7 for the storage and/or display of packaged or bottled product.

ELECTRICAL

- Unit completely pre-wired at factory and ready for final connection to a 208-230V / 60 Hz single phase, 15 amp dedicated outlet. Cord and plug set included.



208-230/60/1
NEMA-6-15R

RECOMMENDED OPERATING CONDITIONS

- Designed to operate in an environment where temperature and humidity do not exceed 75°F (24°C) and 55% relative humidity.
- Unit should not be installed near HVAC vents, fans or doorways that will disrupt the air curtain and compromise the function of the cabinet. Unit should not be installed in direct sunlight.
- Model will run most efficiently when completely loaded with product.
- Drain plumbing hookup recommended.
- Please be advised Air Curtain models are substantially louder than standard refrigeration models.

OPTIONAL FEATURES/ACCESSORIES

Upcharge and lead times may apply.

- 2 1/2" (64 mm) diameter castors (set of 4).
- Variety of sign panels - see our website for the latest color and sign offerings.
- White exterior.
- Stainless steel exterior.
- Black interior liner with black cantilever shelves.
- Additional shelves.
- Stainless steel interior with stainless steel cantilevered shelves.
- Pricing strips.
- Night cover.
- Vandal panel.
- White locking security cover. Standard with flat sign panel. Adds 6 3/4" (171mm) to cabinet height. (Factory Installed with some Field assembly required.)
- Black/bronze locking security cover. Standard with flat sign panel. Adds 6 3/4" (171mm) to cabinet height. (Factory Installed with some Field assembly required.)
- Silver locking security cover. Standard with flat sign panel. Adds 6 3/4" (171mm) to cabinet height. (Factory Installed with some Field assembly required.)
- Condensate pan heater/brackets kit. Connects to 15 amp, 208V outlet located on cabinet. Cannot be hard wired into cabinet.
- Condensate pump kit.

PLAN VIEW

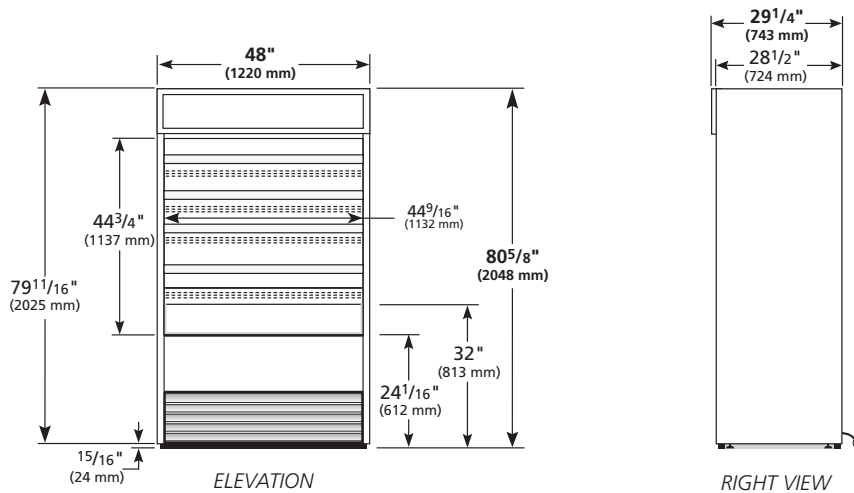

WARRANTY

Three year warranty on all parts and labor and an additional 2 year warranty on compressor. (U.S.A. only)

METRIC DIMENSIONS ROUNDED UP TO THE NEAREST WHOLE MILLIMETER

SPECIFICATIONS SUBJECT TO CHANGE WITHOUT NOTICE



Model	Elevation	Right	Plan	3D	Back
TAC-48~TSL01					

TRUE MANUFACTURING CO., INC.

2001 East Terra Lane • O'Fallon, Missouri 63366-4434 • (636)240-2400 • Fax (636)272-2408 • Toll Free (800)325-6152 • Intl. Fax# (001)636-272-7546 • www.truefmfg.com